

## Aluminium Motor Range

AMA Dimensions, Bearings, Oil Seals & Gland Sizes.....	2
AMA Electrical Data.....	3-5
Multi mounting Arrangements.....	6

## Cast Iron Range

AM1 Dimensions.....	7
AM1 Electrical Data.....	8-14
Shaft Details, Bearings, Oils Seals & Gland Sizes.....	15
General Motor Exploded View.....	16

## Brake Motor Range

AMA-B Dimensions.....	17
AMA-B Electrical Data.....	18

## ATEX Motor Range

ATEX Categories and Designation.....	19
4KTC Zone 1 Dimensions.....	20
4KTC Zone 1 Electrical Data, Terminal Box and Cable Entry.....	21-22
4KTC Zone 1 Brake Motor Dimensions and Electrical Data.....	23-24

## ATEX IP68 Submersible Motor Range

4KTS IP68 Zone 1 Dimensions.....	25
4KTS IP68 Zone 1 Electrical Data.....	26

## Single Phase Motor Range

AMAS-R Capacitor Run Dimensions and Electrical Data.....	27
AMAS-SR Capacitor Start / Capacitor Run Dimensions and Electrical Data.....	28

## Ancillary Product Range

FVU Force Ventilation Unit.....	29
SPB Motor Slide Bases.....	30
SR Motor Slide Rails.....	31
AMRV Worm Reduction Gearboxes.....	32-35

## General Technical Details

Nominal Efficiency, Maximum Sound levels and Increase.....	36-37
Permissible Radial and Axial Loads.....	38-39
Connection Diagrams.....	40
Insulation, Overheating, IP Ratings, Voltage and Frequency, Environmental.....	41-43

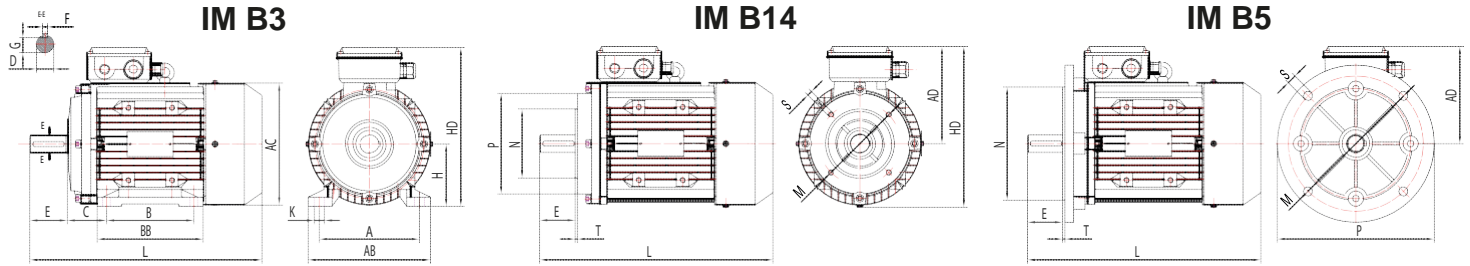

Frame size	A	B	C	D	E	F	G	K	M	N	P	S	T	M	N	P	S	T	M	N	P	S	T	AB	BB	AC	AD	HD	L					
															<b>IM B14</b>		<b>IM B14L</b>		<b>IM B5</b>		<b>IM B5R</b>													
<b>56</b>	90	71	36	9	20	3	7.2	5.8	65	50	80	M5	2.5	85	70	105	M6	2.5	100	80	120	7	3	85	70	105	8	2.5	108	89	110	100	156	195
<b>63</b>	100	80	40	11	23	4	8.5	7	75	60	90	M5	2.5	100	80	120	M6	3	115	95	140	10	3	100	80	120	8	3	120	103	120	109	172	213
<b>71</b>	112	90	45	14	30	5	11	7	85	70	105	M6	2.5	115	95	140	M8	3	130	110	160	10	3.5	115	95	140	10	3	132	104	139	119	189	255
<b>80</b>	125	100	50	19	40	6	15.5	10	100	80	120	M6	3	130	110	160	M8	3.5	165	130	200	12	3.5	130	110	160	10	3.5	160	124	151	135	215	301
<b>90S</b>	140	100	56	24	50	8	20	10	115	95	140	M8	3	130	110	160	M8	3.5	165	130	200	12	3.5	130	110	160	10	3.5	177	125	175	145	235	308
<b>90L</b>	140	125	56	24	50	8	20	10	115	95	140	M8	3	130	110	160	M8	3.5	165	130	200	12	3.5	130	110	160	10	3.5	177	150	175	145	235	360
<b>100L</b>	160	140	63	28	60	8	24	12	130	110	160	M8	3.5	165	130	200	M10	3.5	215	180	250	14.5	4	165	130	200	12	3.5	196	170	196	155	255	372
<b>112M</b>	190	140	70	28	60	8	24	12	130	110	160	M8	3.5	165	130	200	M10	3.5	215	180	250	14.5	4	165	130	200	12	3.5	218	183	219	173	286	394
<b>132S</b>	216	140	89	38	80	10	33	12	165	130	200	M10	3.5	215	180	250	M12	4	265	230	300	14.5	4	215	180	250	14.5	4	252	175	258	192	324	462
<b>132M</b>	216	178	89	38	80	10	33	12	165	130	200	M10	3.5	215	180	250	M12	4	265	230	300	14.5	4	215	180	250	14.5	4	252	218	258	192	324	529
<b>160M</b>	254	210	108	42	110	12	37	15	215	180	250	M12	4						300	250	350	18.5	5	265	230	300	14.5	4	302	304	314	246	406	617
<b>160L</b>	254	254	108	42	110	12	37	15	215	180	250	M12	4						300	250	350	18.5	5	265	230	300	14.5	4	302	304	314	246	406	661

Aluminium three-phase squirrel cage induction motors according to IEC/DIN, multi-mount design with removable feet.

Voltage 220-240/380-420V or 380-420/660-720V, 50Hz, Insulation class F, Class B Temperature rise, Protection IP55, PTC Fitted as standard, Colour RAL 5010. NSK Bearings and Cast iron drive end shield frame 100 and above.

Flange motors B5, B14 small available up to and including size 160. B14 large to 132.

Available in IE1, IE2 and IE3 efficiency. CUS/UL in IE3.

## AMA Bearings, Oil seals & Gland sizes

	Frame size	Poles	Bearing Drive end	Bearing Non-drive end	Oil seal Drive end	Oil seal Non-drive end	Gland size
<b>AMA</b>	56	2-4	6201	6201	12x22x5	12x22x5	M16 x 1.5
<b>AMA</b>	63	2-4	6201	6201	12x24x7	12x24x7	M20 x 1.5
<b>AMA</b>	71	2-8	6202	6202	15x28x7	15x28x7	M20 x 1.5
<b>AMA</b>	80	2-8	6204	6204	20x34x7	20x34x7	M20 x 1.5
<b>AMA</b>	90	2-8	6205	6205	25x37x7	25x37x7	M20 x 1.5
<b>AMA</b>	100	2-8	6206	6206	30x44x7	30x44x7	M20 x 1.5
<b>AMA</b>	112	2-8	6306	6306	30x44x7	30x44x7	M25 x 1.5
<b>AMA</b>	132	2/4-8	6308 / 6308	6208 / 6308	40x58x8	40x58x8	M25 x 1.5
<b>AMA</b>	160	2/4-8	6209 / 6309	6209 / 6209	45x62x8	45x62x8	M32 x 1.5

# AMA IE1 & IE2 (Aluminium) : 2 - Pole - 3000 min<sup>-1</sup> *AMTECS*

Frame size	Rated output power	Rated current at			Full-load speed rpm	Full-load power factor	Full-load efficiency	Full-load torque	Starting current	Starting torque	Pull-out torque	Sound pressure level	Weight foot mounted
		P <sub>N</sub> (KW)	220V I <sub>N</sub> (A)	400V I <sub>N</sub> (A)									
AMA-IE1 56 K2	0.09	0.54	0.31		2758	0.68	62	0.31	5.5	2.2	2.3	49	3.2
AMA-IE1 56 G2	0.12	0.63	0.36		2780	0.71	67	0.41	5.5	2.2	2.3	49	3.4
AMA-IE1 63 K2	0.18	0.87	0.55		2715	0.75	69	0.63	5.5	2.2	2.3	52	4
AMA-IE1 63 G2	0.25	1.14	0.66		2715	0.81	68	0.88	5.5	2.2	2.3	52	4.5
AMA-IE1 71 K2	0.37	1.64	0.94		2690	0.81	70	1.31	6.5	2.2	2.2	54	6
AMA-IE1 71 G2	0.55	2.31	1.33		2715	0.82	73	1.93	6.5	2.2	2.3	54	6.5
AMA-IE2 80 K2	0.75	2.91	1.68		2875	0.93	77.4	2.49	5.30	2.5	3	58	12
AMA-IE2 80 G2	1.1	4.10	2.37		2875	0.84	79.6	3.65	7.00	3.2	3.8	58	13.5
AMA-IE2 90 S2	1.5	5.47	3.16		2890	0.84	81.3	4.96	7.10	2.7	3.5	62	17.5
AMA-IE2 90 L2	2.2	7.76	4.48		2890	0.85	83.2	7.27	6.90	2.4	3	62	22
AMA-IE2 100 L2	3	10.15	5.86		2891	0.87	84.6	9.91	8.00	3.2	4	65	29
AMA-IE2 112 M2	4	13.23	7.64	4.41	2914	0.88	85.8	13.11	7.50	2.5	3	67	32
AMA-IE2 132 S2	5.5		10.6	6.12	2937	0.86	87.0	17.88	7.50	2.7	3.5	70	47.5
AMA-IE2 132 Sx2	7.5		13.9	8.03	2940	0.89	88.1	24.36	7.50	2.4	3.3	70	53
AMA-IE2 160 M2	11		19.9	11.49	2930	0.89	89.4	35.85	7.60	2.2	2.9	71	96
AMA-IE2 160 Mx2	15		26.9	15.53	2930	0.89	90.3	48.89	7.60	2.3	3	71	105
AMA-IE2 160 L2	18.5		33.0	19.05	2937	0.89	90.9	60.15	7.40	2.3	3.1	71	115

# AMA IE1 & IE2 (Aluminium) : 4 - Pole - 1500 min<sup>-1</sup> *AMTECS*

Frame size	Rated output power	Rated current at			Full-load speed rpm	Full-load power factor	Full-load efficiency	Full-load torque	Starting current	Starting torque	Pull-out torque	Sound pressure level	Weight foot mounted
		P <sub>N</sub> (KW)	220V I <sub>N</sub> (A)	400V I <sub>N</sub> (A)									
AMA-IE1 56 K4	0.06	0.57	0.33		1371	0.56	46	0.42	4.4	2.1	2.2	41	3.5
AMA-IE1 56 G4	0.09	0.79	0.45		1350	0.56	49	0.64	4.4	2.1	2.2	41	3.9
AMA-IE1 63 K4	0.12	0.85	0.49		1350	0.64	53	0.85	4.4	2.1	2.2	41	4
AMA-IE1 63 G4	0.18	1.20	0.70		1340	0.66	56	1.28	4.4	2.1	2.2	41	5.3
AMA-IE1 71 K4	0.25	1.30	0.75		1390	0.74	65	1.72	5.2	2.1	2.2	45	6.5
AMA-IE1 71 G4	0.37	1.85	1.06		1375	0.75	67	2.57	5.2	2.1	2.2	45	7
AMA-IE1 80 K4	0.55	2.59	1.49		1370	0.75	71	3.83	5.2	2.1	2.3	49	10.3
AMA-IE2 80 G4	0.75	3.08	1.78		1400	0.76	79.6	5.12	5	2.4	2.9	49	14.5
AMA-IE2 90 S4	1.10	4.38	2.53		1400	0.77	81.4	7.3	6	3	3.5	54	18.5
AMA-IE2 90 L4	1.50	5.87	3.39		1445	0.77	82.8	9.91	6.8	3.2	3.8	54	21
AMA-IE2 100 L4	2.20	8.04	4.64		1440	0.81	84.3	14.6	7	3	3.5	56	31
AMA-IE2 100LX4	3.00	10.70	6.18		1440	0.82	85.5	19.9	7	2.6	3.3	56	37
AMA-IE2 112 M4	4.00	14.06	8.12	4.69	1445	0.82	86.6	26.4	7.5	3.5	4	58	42
AMA-IE2 132 S4	5.50		10.9	6.29	1455	0.83	87.7	36.1	6.4	2.2	2.8	61	52.5
AMA-IE2 132 M4	7.50		14.5	8.37	1455	0.84	88.7	49.2	7	2.4	3	61	64
AMA-IE2 160 M4	11.0		21.0	12.12	1460	0.84	89.8	71.9	6.9	2.5	2.9	63	99
AMA-IE2 160 L4	15.0		28.1	16.22	1460	0.85	90.6	98.1	7.5	2.5	3	63	114
AMA-IE2 160 Lx4	18.5		34.6	20	1470	0.85	90.5	120	7.5	2.2	2.2	69	130

# AMA IE1 & IE2 (Aluminium) : 6 - Pole - 1000 min<sup>-1</sup> *AMTECS*

Frame size	Rated output power	Rated current at			Full-load speed rpm	Full-load power factor	Full-load efficiency	Full-load torque	Starting current	Starting torque	Pull-out torque	Sound pressure level	Weight foot mounted
		P <sub>N</sub> (KW)	220V I <sub>N</sub> (A)	400V I <sub>N</sub> (A)									
AMA-IE1 63 K6	0.09	0.89	0.51		830	0.67	38	1.04	4	1.7	2	42	5.3
AMA-IE1 63 G6	0.12	1.02	0.58		830	0.68	40	1.38	4	1.7	2	42	6
AMA-IE1 71 K6	0.18	1.22	0.70		880	0.63	59	1.95	4	1.9	2	42	6.3
AMA-IE1 71 G6	0.25	1.56	0.90		900	0.68	59	2.65	4	1.9	2	42	6.7
AMA-IE1 80 K6	0.37	2.14	1.23		915	0.7	62	3.86	4.7	1.9	2	49	8.8
AMA-IE1 80 G6	0.55	2.95	1.70		920	0.72	65	5.71	4.7	1.9	2.1	49	10
AMA-IE2 90 S6	0.75	3.43	1.98		934	0.72	75.9	7.67	4.5	2.2	2.4	51	18.5
AMA-IE2 90 L6	1.10	4.88	2.82		945	0.72	78.1	11.1	4.5	2.4	2.6	51	21
AMA-IE2 100 L6	1.50	6.25	3.61		945	0.75	79.8	15.2	4.5	1.8	2.2	53	28.5
AMA-IE2 112 M6	2.20	8.83	5.10		960	0.76	81.8	21.9	4.5	2.3	2.8	58	33.5
AMA-IE2 132 S6	3.00	11.83	6.83		964	0.76	83.3	29.7	4.5	1.8	2.4	58	44
AMA-IE2 132 M6	4.00	15.5	8.96	5.17	965	0.76	84.6	39.6	5	2.9	2.7	59	53
AMA-IE2 132 Mx6	5.50		12	6.93	965	0.77	86.0	54.4	5.5	1.9	2.8	61	63.5
AMA-IE2 160 M6	7.50		15.9	9.18	970	0.78	87.2	73.8	6.5	2	3	61	100
AMA-IE2 160 L6	11.0		22.9	13.22	970	0.78	88.7	108.3	7.5	2.4	3.3	62	113

# AMA IE1 (Aluminium) : 8 - Pole - 750 min<sup>-1</sup> *AMTECS*

Frame size	Rated output power	Rated current at			Full-load speed rpm	Full-load power factor	Full-load efficiency	Full-load torque	Starting current	Starting torque	Pull-out torque	Sound pressure level	Weight foot mounted
		P <sub>N</sub> (KW)	220V I <sub>N</sub> (A)	400V I <sub>N</sub> (A)									
AMA-IE1 71 K8	0.09	0.84	0.48		680	0.55	49	1.26	3.3	1.8	1.9	44	6.5
AMA-IE1 71 G8	0.12	1.10	0.63		690	0.55	50	1.66	3.3	1.8	1.9	44	7
AMA-IE1 80 K8	0.18	1.61	0.93		680	0.55	51	2.53	3.3	1.8	1.9	44	9.5
AMA-IE1 80 G8	0.25	1.91	1.10		680	0.61	54	3.51	3.3	1.8	1.9	44	11.5
AMA-IE1 90 S8	0.37	2.46	1.41		680	0.61	62	5.2	4	1.8	1.9	49	14.6
AMA-IE1 90 L8	0.55	3.59	2.07		700	0.61	63	7.5	4	1.8	2	49	17.6
AMA-IE1 100 L8	0.75	3.96	2.28		700	0.67	71	10.23	4	1.8	2	49	19.5
AMA-IE1 100 Lx8	1.10	5.48	3.15		710	0.69	73	14.80	5	1.8	2	49	21
AMA-IE1 112 M8	1.50	7.28	4.18		710	0.69	75	20.18	5	1.8	2	54	30
AMA-IE1 132 S8	2.20	9.97	5.73		720	0.71	78	29.18	6	1.8	2	58	51
AMA-IE1 132 M8	3.00	13.06	7.51		720	0.73	79	39.79	6	1.8	2	58	56
AMA-IE1 160 M8	4.00	16.8	9.7	5.6	720	0.73	81	53.1	6	2	2	59	60
AMA-IE1 160 Mx8	5.50		12.9	7.4	720	0.74	83	73.0	6	2	2	60	70
AMA-IE1 160 L8	7.50		16.8	9.7	720	0.75	85.5	99.5	6	2	2	60	87
AMA-IE1 160 Lx4	18.5		34.6	20	1470	0.85	90.5	120	7.5	2.2	2.2	69	130

# AMA IE3 (Aluminium) : 2 - Pole - 3000 min<sup>-1</sup>

# AMTECS

Frame size	Rated output power	Rated current at			Full-load speed rpm	Full-load power factor	Full-load efficiency	Full-load torque	Starting current	Starting torque	Pull-out torque	Sound pressure level	Weight foot mounted
		220V I <sub>N</sub> (A)	400V I <sub>N</sub> (A)	690V I <sub>N</sub> (A)									
	P <sub>N</sub> (KW)				n <sub>N</sub> (min <sup>-1</sup> )	cos (φ)	100% (η)	M <sub>N</sub>	I / I <sub>S N</sub>	M <sub>S</sub> / M <sub>N</sub>	M <sub>k</sub> / M <sub>N</sub>	dB(A) 1 meter (no load)	kg
AMA-IE3 80 K2	0.75	2.77	1.6		2880	0.83	80.7	2.49	5.5	1.8	3.5	58	13.5
AMA-IE3 80 G2	1.1	3.98	2.3		2880	0.83	82.7	3.68	7.5	2.6	3.5	58	15
AMA-IE3 90 S2	1.5	5.37	3.1		2895	0.83	84.2	4.95	7.1	2.6	3.5	62	19
AMA-IE3 90 L2	2.2	7.45	4.3		2895	0.85	95.9	7.26	7	2	3	62	21.5
AMA-IE3 100 L2	3	9.70	5.6		2895	0.88	87.1	9.9	8.6	2	3.2	65	30.5
AMA-IE3 112 M2	4	12.82	7.4	4.27	2905	0.88	88.1	13.1	8	1.8	2.9	67	34
AMA-IE3 132 S2	5.5		10	5.77	2930	0.88	98.2	17.9	7.5	2.1	2.5	70	49.5
AMA-IE3 132 Sx2	7.5		14	8.08	2930	0.88	90.1	24.4	7.3	2	3.5	70	55
AMA-IE3 160 M2	11		19	10.97	2945	0.90	91.2	35.7	7.3	2.3	2.6	71	99
AMA-IE3 160 Mx2	15		26	15.01	2945	0.91	91.9	48.6	7	1.9	2.3	71	108
AMA-IE3 160 L2	18.5		32	18.48	2940	0.89	92.4	60.1	7	1.6	2.5	71	118

# AMA IE3 (Aluminium) : 4 - Pole - 1500 min<sup>-1</sup>

# AMTECS

Frame size	Rated output power	Rated current at			Full-load speed rpm	Full-load power factor	Full-load efficiency	Full-load torque	Starting current	Starting torque	Pull-out torque	Sound pressure level	Weight foot mounted
		220V I <sub>N</sub> (A)	400V I <sub>N</sub> (A)	690V I <sub>N</sub> (A)									
	P <sub>N</sub> (KW)				n <sub>N</sub> (min <sup>-1</sup> )	cos (φ)	100% (η)	M <sub>N</sub>	I / I <sub>S N</sub>	M <sub>S</sub> / M <sub>N</sub>	M <sub>k</sub> / M <sub>N</sub>	dB(A) 1 meter (no load)	kg
AMA-IE3 80 G4	0.75	3.07	1.77		1420	0.74	82.5	5.0	6	2.9	3.6	49	16
AMA-IE3 90 S4	1.10	4.42	2.55		1445	0.74	84.1	7.3	6.5	2.7	3.8	54	20
AMA-IE3 90 L4	1.50	5.94	3.43		1445	0.74	85.3	9.9	6.8	3.0	3.6	54	22.5
AMA-IE3 100 L4	2.20	8.11	4.68		1435	0.78	86.7	14.6	7	2.5	3.5	56	32.5
AMA-IE3 100Lx4	3.00	10.95	6.32		1435	0.78	87.7	20.0	7.2	2.6	3.5	56	38.5
AMA-IE3 112 M4	4.00	14.10	8.14	4.70	1440	0.80	88.6	26.5	7	2.3	3.2	58	44
AMA-IE3 132 S4	5.50		11.1	6.41	1460	0.80	89.6	36.0	7	2.7	3.5	61	54.5
AMA-IE3 132 M4	7.50		14.6	8.43	1460	0.82	90.4	49.1	7.1	2.7	3.8	61	66
AMA-IE3 160 M4	11.0		21.2	12.24	1465	0.82	91.4	71.7	7.2	1.9	2.3	63	102
AMA-IE3 160 L4	15.0		28.6	16.51	1465	0.82	92.1	97.8	6.8	1.8	2.4	63	117
AMA 160 Lx4	18.5		34.6	20	1470	0.85	90.5	120	7.5	2.2	2.2	69	130

# AMA IE3 (Aluminium) : 6 - Pole - 1000 min<sup>-1</sup>

# AMTECS

Frame size	Rated output power	Rated current at			Full-load speed rpm	Full-load power factor	Full-load efficiency	Full-load torque	Starting current	Starting torque	Pull-out torque	Sound pressure level	Weight foot mounted
		220V I <sub>N</sub> (A)	400V I <sub>N</sub> (A)	690V I <sub>N</sub> (A)									
	P <sub>N</sub> (KW)				n <sub>N</sub> (min <sup>-1</sup> )	cos (φ)	100% (η)	M <sub>N</sub>	I / I <sub>S N</sub>	M <sub>S</sub> / M <sub>N</sub>	M <sub>k</sub> / M <sub>N</sub>	dB(A) 1 meter (no load)	kg
AMA-IE3 90 S6	0.75	3.81	2.2		935	0.61	78.9	7.86	4.5	2.5	3.3	51	20
AMA-IE3 90 L6	1.10	4.85	2.8		945	0.69	81.0	11.1	4.4	1.7	3.3	51	22.5
AMA-IE3 100 L6	1.50	6.58	3.8		949	0.69	82.5	15.1	5	2.3	3	53	30
AMA-IE3 112 M6	2.20	9.18	5.3		955	0.71	84.3	22	5.5	2.6	3	58	35.5
AMA-IE3 132 S6	3.00	12.30	7.1		968	0.71	85.6	29.6	5.5	2	3.1	58	46
AMA-IE3 132 M6	4.00	16.28	9.4	5.43	968	0.71	86.8	39.5	5.7	2.1	2.6	59	55
AMA-IE3 132 Mx6	5.50		12	6.93	968	0.75	88.0	54.3	6	1.7	2.6	61	65.5
AMA-IE3 160 M6	7.50		16	9.24	970	0.77	89.1	73.8	5.9	1.7	2.5	61	103
AMA-IE3 160 L6	11.0		22	12.70	970	0.79	90.3	108.3	6	1.5	2.4	61	116





**B3 - Foot Mounted**



**B5 - Flange Mounted**



**B14S - Small Face Mounted**



**B3 - Foot Mounted  
(Side Terminal Box)**



**B35 - Foot and Flange**



**B34S - Foot and Small Face**



**B14L - Large Face Mounted**



**B34L - Foot and Large Face**



**V1 - Vertical Flange Mounted  
with Rain Canopy**

*Note: Other mounting arrangements and special shafts are available by request*

# AM1 (Cast Iron) 3 Phase Dimensions

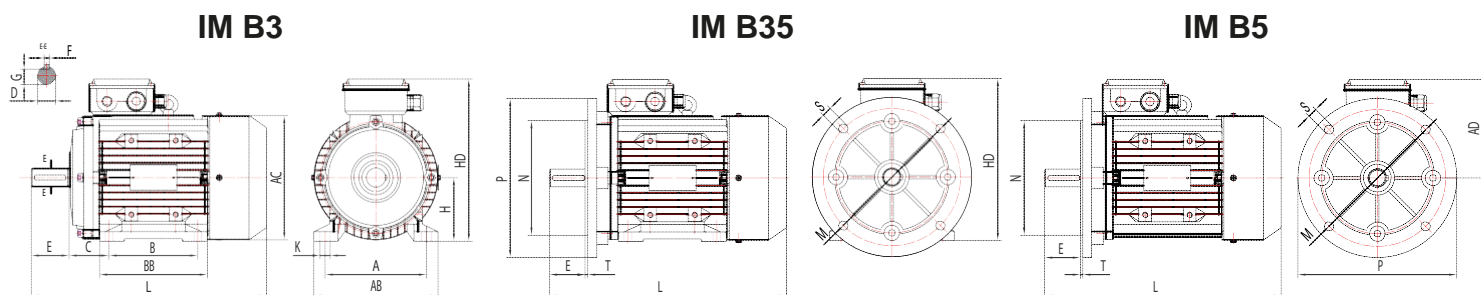

Frame size	A	B	C	D	E	F	G	H	K	M	N	P	S	T	AB	BB	AC	AD	HD	L
80	125	100	50	19	40	6	15.5	80	10	165	130	200	12	3.5	160	130	155	137	217	284
90S	140	100	56	24	50	8	20	90	10	165	130	200	12	3.5	180	140	175	147	237	311
90L	140	125	56	24	50	8	20	90	10	165	130	200	12	3.5	180	165	175	147	237	336
100L	160	140	63	28	60	8	24	100	12	215	180	250	14.5	4	200	176	195	176	276	375
112M	190	140	70	28	60	8	24	112	12	215	180	250	14.5	4	226	180	219	188	300	394
132S	216	140	89	38	80	10	33	132	12	265	230	300	14.5	4	262	186	258	208	340	463
132M	216	178	89	38	80	10	33	132	12	265	230	300	14.5	4	262	224	258	208	340	501
160M	254	210	108	42	110	12	37	160	14.5	300	250	350	18.5	5	314	260	314	255	415	608
160L	254	254	108	42	110	12	37	160	14.5	300	250	350	18.5	5	314	304	314	255	415	652
180M	279	241	121	48	110	14	42.5	180	14.5	300	250	350	18.5	5	349	311	355	272	452	688
180L	279	279	121	48	110	14	42.5	180	14.5	300	250	350	18.5	5	349	349	355	272	452	726
200L	318	305	133	55	110	16	49	200	18.5	350	300	400	18.5	5	388	396	397	302	502	766
225S4-10	356	286	149	60	140	18	53	225	18.5	400	350	450	18.5	5	431	368	446	323	548	806
225M2	356	311	149	55	110	16	49	225	18.5	400	350	450	18.5	5	431	393	446	323	548	801
225M4-10	356	311	149	60	140	18	53	225	18.5	400	350	450	18.5	5	431	393	446	323	548	831
250M2	406	349	168	60	140	18	53	250	24	500	450	550	18.5	5	484	445	485	363	613	910
250M4-10	406	349	168	65	140	18	58	250	24	500	450	550	18.5	5	484	445	485	363	613	910
280S2	457	368	190	65	140	18	58	280	24	500	450	550	18.5	5	542	484	547	392	672	980
280S4-10	457	368	190	75	140	20	67.5	280	24	500	450	550	18.5	5	542	485	547	392	672	980
280M2	457	419	190	65	140	18	58	280	24	500	450	550	18.5	5	542	485	547	392	672	1031
280M4-10	457	419	190	75	140	20	67.5	280	24	500	450	550	18.5	5	542	536	547	392	672	1031
315S2	508	406	216	65	140	18	58	315	28	600	550	660	24	6	536	570	620	515	830	1180
315S4-10	508	406	216	80	170	22	71	315	28	600	550	660	24	6	628	570	620	515	830	1180
315M2	508	457/508	216	65	140	18	58	315	28	600	550	660	24	6	628	680	620	515	830	1290
315M4-10	508	457/508	216	80	170	22	71	315	28	600	550	660	24	6	628	680	620	515	830	1320
315L2	508	457/508	216	65	140	18	58	315	28	600	550	660	24	6	628	680	620	515	830	1290
315L4-10	508	457/508	216	80	170	22	71	315	28	600	550	660	24	6	628	680	620	515	830	1320
355M2	610	560/630	254	75	140	20	67.5	355	28	740	680	800	24	6	750	750	698	630	985	1516
355M4-10	610	560/630	254	100	210	28	90	355	28	740	680	800	24	6	750	750	698	630	985	1546
355L2	610	560/630	254	75	140	20	67.5	355	28	740	680	800	24	6	750	750	698	630	985	1516
355L4-10	610	560/630	254	100	210	28	90	355	28	740	680	800	24	6	750	750	698	630	985	1546

Cast Iron three-phase induction motors according to IEC/DIN, terminal box top mounted, fixed cast feet.

Voltage 220-240/380-420V or 380-420/660-720V, 50Hz, Insulation class F, Protection IP55, PTC Fitted as standard, Colour RAL 5010, NSK Bearings, Re-greaseable bearings on size 160 and above.

Flange motors B5 available up to and including size 280. B35 available on all sizes.

Available in IE1, IE2 and IE3 efficiency. CUS/UL in IE3.

# AM1 IE1 & IE2 (Cast Iron) : 2 - Pole - 3000 min<sup>-1</sup> *AMTECS*

Frame size	Rated output power	Rated current at			Full-load speed rpm	Full-load power factor	Full-load efficiency	Full-load torque	Starting current	Starting torque	Pull-out torque	Sound pressure level	Weight foot mounted
		P <sub>N</sub> (KW)	220V I <sub>N</sub> (A)	400V I <sub>N</sub> (A)									
AM1-IE1 71 K2	0.37	1.64	0.95		2800	0.81	70	1.3	6	2.2	2.2	75	8.6
AM1-IE1 71 G2	0.55	2.31	1.34		2800	0.82	73	1.9	6	2.2	2.2	75	10
AM1-IE2 80K2	0.75	2.9	1.68		2875	0.83	77.4	2.49	5.3	2.5	3	58	18
AM1-IE2 80G2	1.1	4.1	2.37		2875	0.84	79.6	3.65	7.0	3.2	3.8	58	19
AM1-IE2 90S2	1.5	5.5	3.16		2890	0.84	81.3	4.96	7.1	2.7	3.5	62	24
AM1-IE2 90L2	2.2	7.8	4.48		2890	0.85	83.2	7.27	6.9	2.4	3.0	62	27
AM1-IE2 100L2	3	10.1	5.86		2891	0.87	84.6	9.91	8.0	3.2	4.0	65	41
AM1-IE2 112M2	4	13.2	7.64	4.41	2914	0.88	85.8	13.11	7.5	2.5	3.0	67	48
AM1-IE2 132S2	5.5		10.6	6.12	2937	0.86	87.0	17.88	7.5	2.7	3.5	70	73
AM1-IE2 132Sx2	7.5		13.9	8.03	2940	0.88	88.1	24.36	7.5	2.4	3.3	70	81
AM1-IE2 160M2	11		19.9	11.5	2930	0.89	89.4	35.85	7.6	2.2	2.9	71	125
AM1-IE2 160Mx2	15		26.9	15.5	2930	0.89	90.3	48.89	7.6	2.3	3.0	71	137
AM1-IE2 160L2	18.5		33.0	19.1	2937	0.89	90.9	60.15	7.4	2.3	3.1	71	152
AM1-IE2 180M2	22		39.5	22.8	2940	0.88	91.3	71.46	7.8	2.8	3.2	77	187
AM1-IE2 200L2	30		53.4	30.8	2950	0.88	92.0	97.12	7.8	2.6	3.0	80	241
AM1-IE2 200Lx2	37		64.8	37.4	2950	0.89	92.5	119.78	7.7	2.6	3.0	80	261
AM1-IE2 225M2	45		78.4	45.3	2960	0.89	92.9	145.19	7.5	2.4	2.6	81	348
AM1-IE2 250M2	55		94.5	54.6	2965	0.90	93.2	177.15	7.1	2.3	2.8	81	400
AM1-IE2 280S2	75		128	73.9	2970	0.90	93.8	241.16	7.4	2.5	2.8	82	540
AM1-IE2 280M2	90		152	87.8	2970	0.91	94.1	289.39	7.6	2.8	2.8	82	588
AM1-IE2 315S2	110		185	106.8	2975	0.91	94.3	353.11	6.9	2.4	2.8	84	948
AM1-IE2 315M2	132		221	127.6	2975	0.91	94.6	423.73	7.1	2.6	2.9	84	1009
AM1-IE2 315L2	160		265	153.0	2975	0.92	94.8	513.61	7.1	2.5	2.9	87	1111
AM1-IE2 315Lx2	200		330	190.5	2975	0.92	95.0	642.02	6.9	2.5	2.8	87	1142
AM1-IE2 355M2	250		412	237.9	2980	0.92	95.0	801.17	7.0	2.5	2.8	90	1938
AM1-IE2 355Lx2	315		520	300.2	2980	0.92	95.0	1009.48	7.0	2.5	2.9	90	2346



# AM1 IE1 & IE2 (Cast Iron) : 4 - Pole - 1500 min<sup>-1</sup> *AMTECS*

Frame size	Rated output power	Rated current at			Full-load speed rpm	Full-load power factor	Full-load efficiency	Full-load torque	Starting current	Starting torque	Pull-out torque	Sound pressure level	Weight foot mounted
		P <sub>N</sub> (KW)	220V I <sub>N</sub> (A)	400V I <sub>N</sub> (A)									
AM1-IE1 71 K4	0.25	0.74	0.75		1370	0.74	65	1.7	4.5	2.2	2.2	65	8.4
AM1-IE1 71 G4	0.37	1.00	1.07		1370	0.75	67	2.5	4.5	2.2	2.2	70	9.7
AM1-IE1 80 K4	0.55	1.31	1.5		1400	0.75	71	3.8	5.5	2.2	2.2	70	16
AM1-IE2 80G4	0.75	3.08	1.78		1400	0.76	79.6	5.12	5	2.4	2.9	49	20
AM1-IE2 90S4	1.1	4.38	2.53		1440	0.77	81.4	7.3	6	3	3.5	54	25
AM1-IE2 90L4	1.5	5.87	3.39		1445	0.77	82.8	9.91	6.8	3.2	3.8	54	30
AM1-IE2 100L4	2.2	8.04	4.64		1440	0.81	84.3	14.6	7	3	3.5	56	42
AM1-IE2 100Lx4	3	10.70	6.18		1140	0.82	85.5	19.9	7.5	2.6	3.3	56	47
AM1-IE2 112M4	4	14.06	8.12	4.69	1445	0.82	86.6	26.4	7	3	3.5	58	53
AM1-IE2 132S4	5.5		10.9	6.29	1455	0.83	87.7	36.1	6.4	2.2	2.8	61	78
AM1-IE2 132M4	7.5		14.5	8.37	1455	0.84	88.7	49.2	7	2.4	3	61	88
AM1-IE2 160M4	11		21	12.12	1460	0.84	89.8	71.9	6.9	2.5	2.9	63	138
AM1-IE2 160L4	15		28.1	16.22	1460	0.85	90.6	98.1	7.5	2.5	3	63	148
AM1-IE2 180M4	18.5		34	19.63	1470	0.86	91.2	120.2	7.8	2.6	3.1	69	185
AM1-IE2 180L4	22		40.2	23.21	1470	0.86	91.6	142.9	7.5	2.6	3.1	69	210
AM1-IE2 200L4	30		54.4	31.41	1470	0.86	92.3	194.9	7.1	2.4	2.9	70	270
AM1-IE2 225S4	37		66.2	38.22	1480	0.87	92.7	238.8	7.5	2.5	2.7	71	310
AM1-IE2 225M4	45		80.1	46.25	1480	0.87	93.1	290.4	7.6	2.5	2.8	71	340
AM1-IE2 250M4	55		97.5	56.29	1480	0.87	93.5	354.9	7.3	2.6	2.7	71	413
AM1-IE2 280S4	75		132	76.21	1480	0.87	94	484	7.6	2.7	2.7	73	530
AM1-IE2 280M4	90		158	91.22	1480	0.87	94.2	580.7	7.5	2.7	2.7	73	630
AM1-IE2 315S4	110		191	110.27	1485	0.88	94.5	707.4	7.1	2.7	2.9	80	950
AM1-IE2 315M4	132		228	131.64	1485	0.88	94.7	88.9	7.3	2.7	2.9	80	1037
AM1-IE2 315L	160		273	157.62	1485	0.89	94.9	1029	7.4	3	3	84	1107
AM1-IE2 315Lx	200		341	196.88	1485	0.89	95.1	1286	7.6	3	3	84	1225
AM1-IE2 355M	250		421	243.06	1490	0.9	95.1	1602	7.5	2.8	2.9	88	1734
AM1-IE2 355Lx	315		531	306.57	1490	0.9	95.1	2019	7.4	2.6	2.8	88	1940

# AM1 IE1 & IE2 (Cast Iron) : 6 - Pole - 1000 min<sup>-1</sup> *AMTECS*

Frame size	Rated output power	Rated current at			Full-load speed rpm	Full-load power factor	Full-load efficiency	Full-load torque	Starting current	Starting torque	Pull-out torque	Sound pressure level	Weight foot mounted
		P <sub>N</sub> (KW)	220V I <sub>k</sub> (A)	400V I <sub>k</sub> (A)									
AM1-IE1 71 K6	0.18	1.23	0.7		880	0.66	92	2.0	6	2.2	2.4	52	8.4
AM1-IE1 71 G6	0.25	1.57	0.9		880	0.68	92	2.7	6	2.2	2.4	52	9.2
AM1-IE1 80 K6	0.37	2.1	1.2		900	0.7	92.5	3.9	6	2.2	2.4	54	17
AM1-IE1 80 G6	0.55	3	1.7		900	0.72	92.8	5.7	6	2.2	2.4	54	18
AM1-IE2 90S6	0.75	3.43	1.98		934	0.72	75.9	7.67	4.5	2.2	2.4	51	25
AM1-IE2 90L6	1.1	4.88	2.82		945	0.72	78.1	11.1	4.5	2.4	2.6	51	27
AM1-IE2 100L6	1.5	6.25	3.61		945	0.75	79.8	15.2	4.2	1.8	2.2	53	40
AM1-IE2 112M6	2.2	8.83	5.1		960	0.76	81.8	21.9	4.5	2.3	2.8	58	5
AM1-IE2 132S6	3	11.83	6.83		964	0.76	83.3	29.7	4.5	1.8	2.4	58	76
AM1-IE2 132M6	4	15.52	8.96	5.17	965	0.76	84.6	39.6	5	2.3	2.7	59	83
AM1-IE2 132Mx6	5.5		12	6.93	965	0.77	96	54.4	5.5	1.9	2.8	61	95
AM1-IE2 160M6	7.5		15.9	9.18	970	0.78	87.2	73.8	6.5	2	3	61	151
AM1-IE2 160L6	11		22.9	13.22	970	0.78	88.7	108.3	7.5	2.4	3.3	62	167
AM1-IE2 180L6	15		29.8	17.21	975	0.81	89.7	146.9	6.4	2	2.7	62	198
AM1-IE2 200L6	18.5		36.4	21.02	980	0.81	90.4	180.3	7	2.3	3	63	236
AM1-IE2 200Lx6	22		42	24.25	980	0.83	90.9	214.4	7	2.3	2.8	63	251
AM1-IE2 225M6	30		56.2	32.45	980	0.84	91.7	292.3	6.5	2.2	2.7	64	317
AM1-IE2 250M6	37		67.3	38.86	980	0.86	92.2	360.6	6.9	2.5	2.7	66	397
AM1-IE2 280S6	45		81.5	47.05	980	0.86	92.7	438.5	7	2.2	2.4	68	513
AM1-IE2 280M6	55		99.2	57.27	980	0.86	93.1	536	7.1	2.4	2.5	68	562
AM1-IE2 315S6	75		134	77.36	985	0.86	93.7	727.2	7.3	2.8	3	73	933
AM1-IE2 315M6	90		160	92.38	985	0.86	94	872.6	7.1	2.7	2.9	73	1013
AM1-IE2 315L6	110		196	113.16	985	0.86	94.3	1066	7.4	2.9	2.9	73	1086
AM1-IE2 315Lx6	132		231	133.37	985	0.87	94.6	1280	7.6	3	3.1	73	1208
AM1-IE2 355M6	160		277	159.93	990	0.88	94.8	1543	7.6	3.1	3.1	80	1581
AM1-IE2 355Mx6	200		345	199.19	990	0.88	95	1929	7.8	3	3	80	1632
AM1-IE2 355Lx6	250		432	249.42	990	0.88	95	2412	7.7	3.1	3	80	1734

Frame size	Rated output power	Rated current at			Full-load speed rpm	Full-load power factor	Full-load efficiency	Full-load torque	Starting current	Starting torque	Pull-out torque	Sound pressure level	Weight foot mounted
		P <sub>N</sub> (KW)	220V I <sub>k</sub> (A)	400V I <sub>k</sub> (A)									
AM1-IE1 71 Gx8	0.18	1.5	0.8		680	0.61	51	2.5	3.3	1.8	1.9	52	9.1
AM1-IE1 71 Gy8	0.25	1.9	1.1		680	0.61	54	3.5	3.3	1.8	1.9	52	10.3
AM1-IE1 90 S8	0.37	2.5	1.4		680	0.61	62	5.2	4	1.8	1.9	56	21
AM1-IE1 90 L8	0.55	3.6	2.1		700	0.61	63	7.5	4	1.8	2	56	23
AM1-IE1 100 L8	0.75	4	2.3		700	0.67	71	10.2	4	1.8	2	59	30
AM1-IE1 100 Lx8	1.10	5.5	3.1		700	0.69	73	15.0	5	1.8	2	59	33
AM1-IE1 112 M8	1.50	7.4	4.3		710	0.69	75	20.2	5	1.8	2	61	42
AM1-IE1 132 S8	2.20	9.9	5.7		710	0.71	78	29.6	6	2	2	64	60
AM1-IE1 132 M8	3.00	13.1	7.5		710	0.73	79	40.4	6	2	2	64	76
AM1-IE1 160 M8	4.00	16.9	9.7	5.6	720	0.73	81	53.1	6	2	2	68	112
AM1-IE1 160 Mx8	5.50		12.9	7.5	720	0.74	83	73.0	6	2	2	68	116
AM1-IE1 160 L8	7.50		16.8	9.7	720	0.75	85.5	99.5	6	2	2	68	118
AM1-IE1 180 L8	11.0		23.8	13.8	730	0.76	87.5	144	6.5	2	2	70	166
AM1-IE1 200 L8	15.0		32.3	18.7	730	0.76	88	196	6.5	2	2	73	214
AM1-IE1 225 S8	18.5		28.6	22.4	740	0.76	90	239	6.6	1.9	2	3	255
AM1-IE1 225 M8	22.0		45	26.1	740	0.78	90.5	284	6.6	1.9	2	73	284
AM1-IE1 250 M8	30.0		60.8	35.2	740	0.79	91	387	6.6	1.9	2	75	380
AM1-IE1 280 S8	37.0		74.1	43	740	0.79	91.5	478	6.6	1.9	2	76	496
AM1-IE1 280 M8	45.0		89.3	51.8	740	0.79	92	581	6.6	1.9	2	76	520
AM1-IE1 315 S8	55.0		105	61.1	740	0.81	92.8	710	6.6	1.8	2	82	815
AM1-IE1 315 M8	75.0		143	83.2	740	0.81	93	968	6.6	1.8	2	82	920
AM1-IE1 315 L8	90.0		169	98	740	0.82	93.8	1161	6.6	1.8	2	82	1020
AM1-IE1 315 Lx8	110		206	120	740	0.82	94	1420	6.4	1.8	2	82	1430
AM1-IE1 355 M8	132		248	144	740	0.82	93.7	1704	6.4	1.8	2	82	1570
AM1-IE1 355 Mx8	160		297	172	740	0.82	94.2	2065	6.4	1.8	2	82	1600

Frame size	Rated output power	Rated current at			Full-load speed rpm	Full-load power factor	Full-load efficiency	Full-load torque	Starting current	Starting torque	Pull-out torque	Sound pressure level	Weight foot mounted
		220V I <sub>k</sub> (A)	400V I <sub>k</sub> (A)	690V I <sub>k</sub> (A)									
AM1-IE3 80K2	0.75	2.79	1.61		2880	0.83	80.7	2.49	5.5	1.8	3.5	58	20
AM1-IE3 80G2	1.1	4.00	2.31		2880	0.83	82.7	3.65	7.5	2.6	3.5	58	21
AM1-IE3 90S2	1.5	5.35	3.09		2895	0.83	84.2	4.95	7.1	2.6	3.5	62	26
AM1-IE3 90L2	2.2	7.52	4.34		2895	0.85	85.9	7.26	7	2	3	62	29
AM1-IE3 100L2	3	9.77	5.64		2895	0.88	87.1	9.9	8.6	2	3.2	65	43
AM1-IE3 112M2	4	12.89	7.44	4.30	2905	0.88	88.1	13.1	8	1.8	2.9	67	51
AM1-IE3 132S2	5.5		10.1	5.83	2930	0.88	89.2	17.9	7.5	2.1	2.5	70	76
AM1-IE3 132Sx2	7.5		13.7	7.91	2930	0.88	90.1	24.4	7.3	2	3.5	70	84
AM1-IE3 160M2	11		19.3	11.14	2945	0.9	91.2	25.7	7.3	2.3	2.6	71	128
AM1-IE3 160Mx2	15		25.9	14.95	2945	0.91	91.9	48.6	7	1.9	2.3	71	140
AM1-IE3 160L2	18.5		32.4	18.71	2940	0.89	92.4	60.1	7	1.6	2.5	71	155
AM1-IE3 180M2	22		38.1	22.00	2955	0.9	92.7	71.1	7	1.6	2.5	77	192
AM1-IE3 200L2	30		52.1	30.08	2960	0.89	93.3	96.8	7	1.5	2.5	80	246
AM1-IE3 200Lx2	37		62.6	36.14	2960	0.91	93.7	119	7.3	1.5	2.5	80	267
AM1-IE3 225M2	45		78.4	45.26	2965	0.88	94	145	6.8	1.6	2.5	81	353
AM1-IE3 250M2	55		94.6	54.62	2970	0.89	94.3	176.9	7.2	1.6	2.6	81	408
AM1-IE3 280S2	75		127	73.32	2975	0.91	94.7	240.8	7.2	1.2	2	82	548
AM1-IE3 280M2	90		153	88.33	2975	0.89	95	288.9	7.4	1.2	2	82	596
AM1-IE3 315S2	110		185	106.81	2978	0.9	95.2	352.8	7.3	1.2	2	84	956
AM1-IE3 315M2	132		222	128.17	2978	0.9	95.4	432.3	7.3	1.3	2.1	84	1017
AM1-IE3 315L2	160		268	154.73	2980	0.9	95.6	512.8	6.8	1.2	2	87	1109
AM1-IE3 315Lx2	200		331	191.10	2980	0.91	95.8	640.9	7.8	1.1	2	87	1150
AM1-IE3 355M2	250		409	236.14	2982	0.92	95.8	800.6	7.9	1.1	2	90	1948
AM1-IE3 355Lx2	315		519	299.64	2982	0.92	95.8	1009	7.9	1.1	2	90	2356

Frame size	Rated output power	Rated current at			Full-load speed rpm	Full-load power factor	Full-load efficiency	Full-load torque	Starting current	Starting torque	Pull-out torque	Sound pressure level	Weight foot mounted
		P <sub>N</sub> (KW)	220V I <sub>N</sub> (A)	400V I <sub>N</sub> (A)									
AM1-IE3 80G4	0.75	3.07	1.77		1420	0.74	82.5	5.04	6	2.9	3.6	49	22
AM1-IE3 90S4	1.1	4.42	2.55		1445	0.74	84.1	7.27	6.5	2.7	3.8	54	27
AM1-IE3 90L4	1.5	5.94	3.43		1445	0.74	85.3	9.91	6.8	3	3.6	54	32
AM1-IE3 100L4	2.2	8.11	4.68		1435	0.78	86.7	14.6	7.2	2.5	3.5	56	44
AM1-IE3 100Lx4	3	10.95	6.32		1435	0.78	87.7	20	7.2	2.6	3.5	56	49
AM1-IE3 112M4	4	14.10	8.14	4.70	1440	0.80	88.6	26.5	7	2.3	3.2	58	56
AM1-IE3 132S4	5.5		11.1	6.41	1460	0.80	89.6	36	7.1	2.7	3.5	61	81
AM1-IE3 132M4	7.5		14.6	8.43	1460	0.82	90.4	49.1	7.2	2.7	3.8	61	91
AM1-IE3 160M4	11		21.2	12.24	1465	0.82	91.4	71.7	6.8	1.9	2.3	63	141
AM1-IE3 160L4	15		28.6	16.51	1465	0.82	92.1	97.8	6.8	1.8	2.4	63	151
AM1-IE3 180M4	18.5		34.3	19.80	1470	0.84	92.6	120.2	6.9	1.8	2.5	69	190
AM1-IE3 180L4	22		40.2	23.21	1470	0.85	93	142.9	7	1.8	2.5	69	205
AM1-IE3 200L4	30		53.7	31.00	1475	0.86	93.6	194.2	6.8	1.8	2.3	70	275
AM1-IE3 225S4	37		66.1	38.16	1485	0.86	93.9	237.9	7.1	1.7	2.3	71	315
AM1-IE3 225M4	45		79.1	45.67	1485	0.87	94.2	289.4	7.1	1.8	2.4	71	345
AM1-IE3 250M4	55		96.2	55.54	1485	0.87	94.6	353.7	7	1.8	2.4	71	421
AM1-IE3 280S4	75		131	75.63	1486	0.87	95	482	6.9	1.8	2.2	73	538
AM1-IE3 280M4	90		157	90.64	1486	0.87	95.2	578.4	7.2	1.6	2.1	73	638
AM1-IE3 315S4	110		189	109.12	1488	0.88	95.4	706	7.2	1.6	2.1	80	958
AM1-IE3 315M4	132		226	130.48	1488	0.88	95.6	847.2	7.2	1.5	2	80	1045
AM1-IE3 315L	160		274	158.19	1488	0.88	95.8	1027	6.8	1.5	2	84	1115
AM1-IE3 315Lx	200		342	197.45	1490	0.88	96	1282	7.2	1.6	2.1	84	1233
AM1-IE3 355M	250		427	246.53	1490	0.88	96	1603	7.3	1.4	2.1	88	1744
AM1-IE3 355Lx	315		538	310.61	1490	0.88	96	2019	7.4	1.4	2	88	1950

Frame size	Rated output power	Rated current at			Full-load speed rpm	Full-load power factor	Full-load efficiency	Full-load torque	Starting current	Starting torque	Pull-out torque	Sound pressure level	Weight foot mounted
		220V I <sub>N</sub> (A)	400V I <sub>N</sub> (A)	690V I <sub>N</sub> (A)									
	P <sub>N</sub> (KW)				n <sub>N</sub> (min <sup>-1</sup> )	cos (φ)	100% (η)	M <sub>N</sub>	I <sub>s</sub> /I <sub>N</sub>	M <sub>s</sub> /M <sub>N</sub>	M <sub>k</sub> /M <sub>N</sub>	dB(A) 1 meter (no load)	kg
AM1-IE3 90S6	0.75	3.88	2.24		935	0.61	78.9	7.66	4.5	2.5	3.3	51	27
AM1-IE3 90L6	1.1	4.92	2.84		945	0.69	81	11.1	4.4	1.7	3.3	51	29
AM1-IE3 100L6	1.5	6.58	3.8		949	0.69	82.5	15.1	5	2.3	3	53	42
AM1-IE3 112M6	2.2	9.18	5.3		955	0.71	84.3	22	5.5	2.6	3	58	53
AM1-IE3 132S6	3	12.31	7.11		968	0.71	85.6	29.6	5.5	2	3.1	58	79
AM1-IE3 132M6	4	16.21	9.36	5.40	968	0.71	86.8	39.5	5.7	2.1	2.6	59	86
AM1-IE3 132Mx6	5.5		12	6.93	968	0.75	88	54.3	6	1.7	2.6	61	98
AM1-IE3 160M6	7.5		15.7	9.06	970	0.77	89.1	73.8	5.9	1.7	2.5	61	154
AM1-IE3 160L6	11		22.2	12.82	970	0.79	90.3	108.3	6	1.5	2.4	62	170
AM1-IE3 180L6	15		29.3	16.92	978	0.81	91.2	146.5	6	1.5	2.4	62	203
AM1-IE3 200L6	18.5		35.9	20.73	980	0.81	91.7	180.3	6.5	1.6	2.4	63	241
AM1-IE3200Lx6	22		41.4	23.90	980	0.83	92.2	214.4	6	1.7	2.3	63	256
AM1-IE3 225M6	30		55.4	31.99	980	0.84	92.9	292.3	6.5	1.9	2.2	64	322
AM1-IE3 250M6	37		68.1	39.32	985	0.84	93.3	385.7	6.8	1.9	2.2	66	405
AM1-IE3 280S6	45		81.5	47.05	985	0.85	93.7	436.3	6.5	1.8	2.2	68	521
AM1-IE3 280M6	55		99.1	57.22	985	0.85	94.1	533.2	6	1.8	2.2	68	570
AM1-IE3 315S6	75		135	77.94	985	0.85	94.6	727.2	6.5	1.6	2	73	941
AM1-IE3 315M6	90		161	92.95	988	0.85	94.9	869.9	6.8	1.6	2	73	1021
AM1-IE3 315L6	110		194	112.01	988	0.86	95.1	1063	6.8	1.5	2	73	1094
AM1-IE3 315Lx6	132		232	133.95	988	0.86	95.4	1276	6.8	1.4	2.1	73	1216
AM1-IE3 355M6	160		281	162.24	990	0.86	95.6	1543	7.1	1.4	2	80	1591
AM1-IE3 355Mx6	200		342	197.45	990	0.88	95.8	1929	7.2	1.3	2	80	1642
AM1-IE3 355Lx6	250		428	247.11	990	0.88	95.8	2412	7.2	1.3	2	80	1744
AM1-IE3 355Lx	315		538	310.61	1490	0.88	96	2019	7.4	1.4	2	88	1950



	Frame size	Poles	Bearing Drive end	Bearing Non-drive end	Oil seal Drive end	Oil seal Non-drive end	Gland size
<b>AM1</b>	71	2 - 8	6202	6202	15x28x7	15x28x7	M20 x 1.5
<b>AM1</b>	80	2 - 8	6204	6204	20x34x7	20x34x7	M20 x 1.5
<b>AM1</b>	90	2 - 8	6205	6205	25x37x7	25x37x7	M20 x 1.5
<b>AM1</b>	100	2 - 8	6206	6206	30x44x7	30x44x7	M25 x 1.5
<b>AM1</b>	112	2 - 8	6306	6306	30x44x7	30x44x7	M25 x 1.5
<b>AM1</b>	132	2 - 8	6308	6308	40x58x8	40x58x8	M25 x 1.5
<b>AM1</b>	160	2 / 4 - 8	6209 / 6309	6209	62x45x8	62x45x8	M32 x 1.5
<b>AM1</b>	180	2 / 4 - 8	6211 / 6311	6211	72x55x8	72x55x8	M32 x 1.5
<b>AM1</b>	200	2 / 4 - 8	6212 / 6312	6212	75x60x8	75x60x8	M40 x 1.5
<b>AM1</b>	225	2 / 4 - 8	6312 / 6313	6312	75x60x8 / 85x65x12	75x60x8	M40 x 1.5
<b>AM1</b>	250	2 / 4 - 8	6313 / 6314	6313	85x65x12 / 90x70x12	85x65x12	M63 x 1.5
<b>AM1</b>	280	2 / 4 - 8	6314 / 6317	6314	90x70x12 / 100x85x12	90x70x12	M63 x 1.5
<b>AM1</b>	315	2 / 4 - 8	6317 / N319	6317 / 6319	100x85x12 / 120x95x13	100x85x12 / 120x95x13	M63 x 1.5
<b>AM1</b>	355	2 / 4 - 8	6319 / N322	6319 / 6322	120x95x13 / 130x110x13	120x95x13 / 130x110x13	M63 x 1.5

## Shaft Dimensions and Tolerances

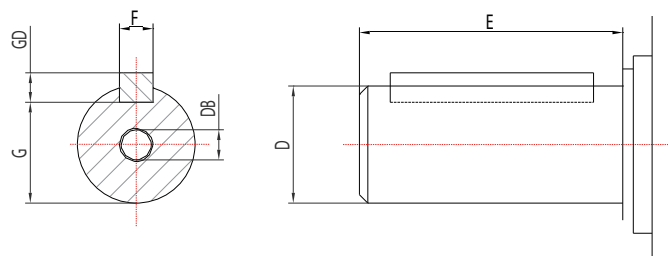

Frame size	D	E	F	G	GD	DB
	(mm)	(mm)	(mm)	(mm)	(mm)	(mm)
<b>56</b>	9j6	20	3	7	3	M3
<b>63</b>	11j6	23	4	8.5	4	M4
<b>71</b>	14j6	30	5	11	5	M5
<b>80</b>	19j6	40	6	15.5	6	M6
<b>90</b>	24j6	50	8	20	7	M8
<b>100</b>	28j6	60	8	24	7	M10
<b>112</b>	28j6	60	8	24	7	M10
<b>132</b>	38k6	80	10	33	8	M12
<b>160</b>	42k6	110	12	37	8	M16
<b>180</b>	48k6	110	14	42.5	9	M16
<b>200</b>	55m6	110	16	49	10	M20
<b>225S4-10</b>	60m8	140	18	53	11	M20
<b>225M2</b>	55m6	110	16	49	10	M20
<b>225M4-10</b>	60m6	140	18	53	11	M20
<b>250M2</b>	60m6	140	18	53	11	M20
<b>250M4-10</b>	65m6	140	18	58	11	M20
<b>280S2</b>	65m6	140	18	58	11	M20
<b>280S4-10</b>	75m6	140	20	67.5	12	M20
<b>280M2</b>	65m6	140	18	58	11	M20
<b>280M4-10</b>	75m6	140	20	67.5	12	M20
<b>315S2</b>	65m6	140	18	58	11	M20
<b>315S4-10</b>	80m6	170	22	71	14	M20
<b>315M2</b>	65m6	140	18	58	11	M20
<b>315M4-10</b>	80m6	170	22	71	14	M20
<b>315L2</b>	65m6	140	18	58	11	M20
<b>315L4-10</b>	80m6	170	22	71	14	M20
<b>355M2</b>	75m6	140	20	67.5	12	M20
<b>355M4-10</b>	100m6	210	28	90	16	M24
<b>355L2</b>	75m6	140	20	67.5	12	M20
<b>355L4-10</b>	100m6	210	28	90	16	M24

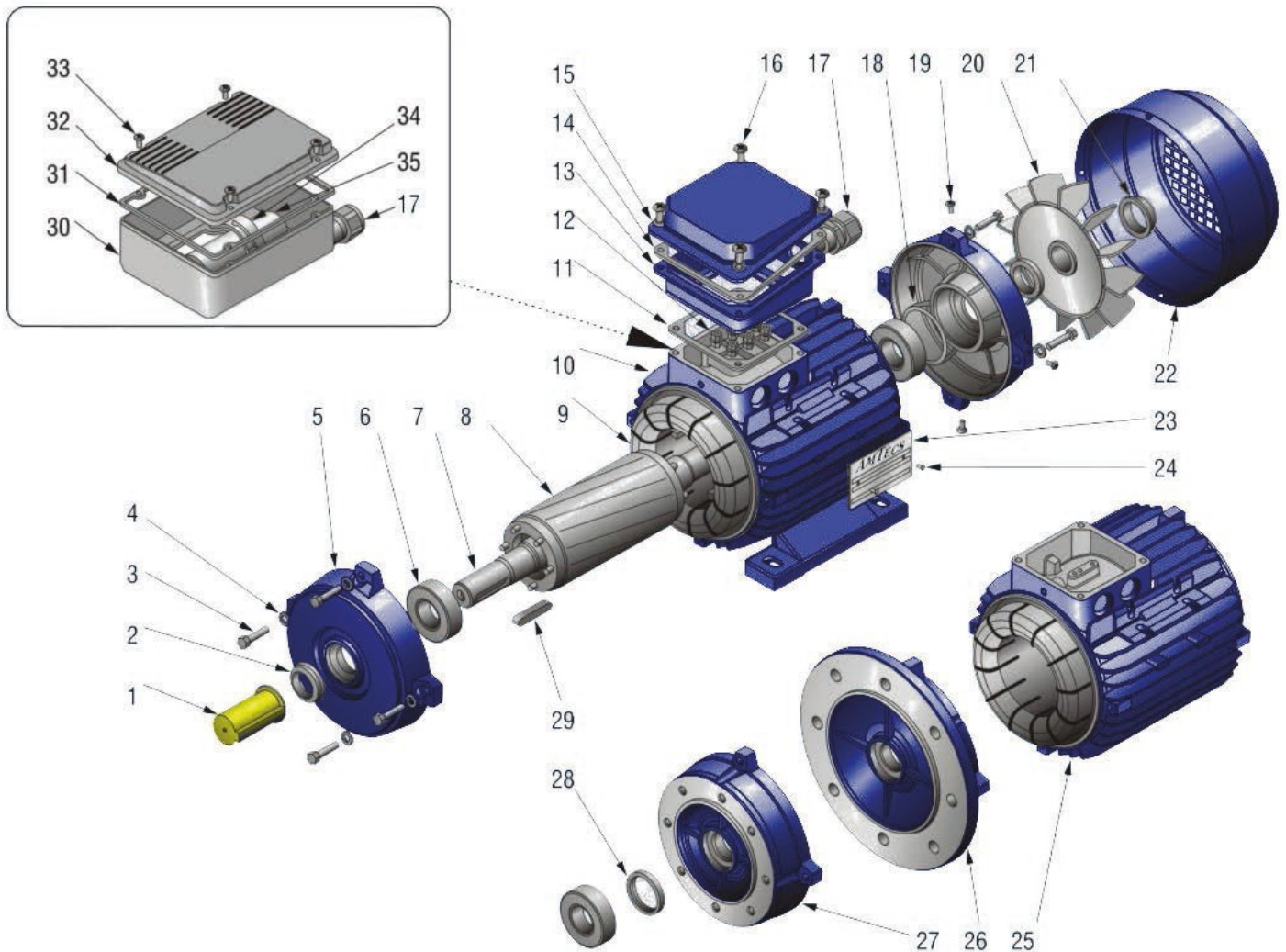

- 1. Shaft Cover
- 2. Oil Seal
- 3. Endshield fixing bolt
- 4. Endshield shake-proof washer
- 5. B3 Drive-end endshield
- 6. Drive-end bearing
- 7. Shaft
- 8. Rotor
- 9. Stator winding
- 10. Stator housing
- 11. Lower terminal box gasket
- 12. Terminal block

- 13. Lower terminal box
- 14. Terminal box gasket
- 15. Terminal box lid
- 16. Terminal box screw
- 17. Cable gland
- 18. Spring washer
- 19. Fan cowl fixing screw
- 20. Cooling fan
- 21. Cooling fan retaining clip
- 22. Fan cowl
- 23. Nameplate
- 24. Nameplate fixing screw

- 25. Stator housing
- 26. B5 Drive-end endshield
- 27. B14 Drive-end endshield
- 28. Oil Seal
- 29. Key
- 30. Terminal box
- 31. Terminal box gasket
- 32. Terminal box lid
- 33. Terminal box screw
- 34. Capacitor retaining clip
- 35. Capacitor

*Note: Exploded view is for illustration purposes only as the design can vary from type to type*

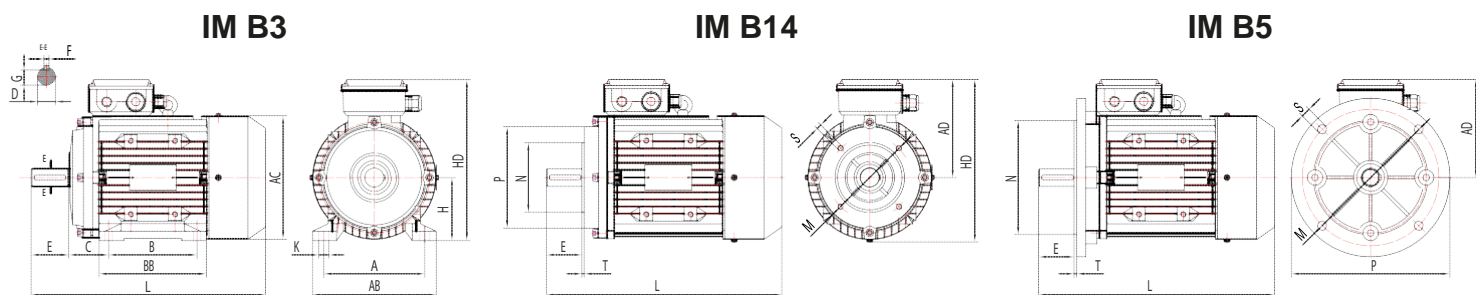

Frame Size	A	B	C	D	E	F	G	H	K	M	N	P	S	T	M	N	P	S	T	M	N	P	S	T	AB	BB	AC	AD	HD	L					
<b>56</b>	90	71	36	9	20	3	7.2	56	5.8	65	50	80	M5	2.5	85	70	105	M6	2.5	100	80	120	7	3	108	89	110	100	156						
<b>63</b>	100	80	40	11	23	4	8.5	63	7	75	60	90	M5	2.5	100	80	120	M6	3	115	95	140	10	3	125	103	120	109	172	250					
<b>71</b>	112	90	45	14	30	5	11	71	7	85	70	105	M6	2.5	115	95	140	M8	3	130	110	160	10	3.5	140	113	140	110	181	290					
<b>80</b>	125	100	50	19	40	6	15.5	80	10	100	80	120	M6	3	130	110	160	M8	3.5	165	130	200	12	3.5	155	122	158	135	215	337					
<b>90S</b>	140	100	56	24	50	8	20	90	10	115	95	140	M8	3	130	110	160	M8	3.5	165	130	200	12	3.5	175	155	175	145	235	385					
<b>90L</b>	140	125	56	24	50	8	20	90	10	115	95	140	M8	3	130	110	160	M8	3.5	165	130	200	12	3.5	175	155	175	145	235	385					
<b>100L</b>	160	140	63	28	60	8	24	100	12	130	110	160	M8	3.5	165	130	200	M10	3.5	215	180	250	14.5	4	205	176	196	155	255	445					
<b>112M</b>	190	140	70	28	60	8	24	112	12	130	110	160	M8	3.5	165	130	200	M10	3.5	215	180	250	14.5	4	235	180	220	170	282	455					
<b>132S</b>	216	140	89	38	80	10	33	132	12	165	130	200	M10	3.5	215	180	250	M12	4	265	230	300	14.5	4	266	180	260	190	322	540					
<b>132M</b>	216	178	89	38	80	10	33	132	12	165	130	200	M10	3.5	215	180	250	M12	4	265	230	300	14.5	4	266	218	260	190	322	580					

Aluminium and cast iron three-phase squirrel cage induction brake motors with hand release according to IEC/DIN. Aluminium and Aluminium high output have multi-mount design, with removable feet. Voltage 220-240/380-420V or 380-420/660-720V, 50Hz, Insulation class F, Class B Temperature rise, Protection IP55, Colour RAL5010, NSK Bearings, DC Brake with halfwave rectifier.  
 Flange motors B5, B14 small available up to and including size 160. B14 large to 132.

Frame size	Rated output power	Rated current at			Full-load speed rpm	Full-load power factor	Full-load efficiency	Brake Voltage	Static braking torque	No-load brake response time	Brake power	Full-load torque	Starting current	Starting torque	Pull-out torque	Sound pressure level	Weight foot mounted
		P <sub>N</sub> (KW)	220V I <sub>N</sub> (A)	400V I <sub>N</sub> (A)													
					n <sub>N</sub> (min <sup>-1</sup> )	cos (φ)	100% (η)	V (Vdc)	(Nm)	(ms)	(W)	M <sub>N</sub>	I <sub>S</sub> /I <sub>N</sub>	M <sub>S</sub> /M <sub>N</sub>	M <sub>K</sub> /M <sub>N</sub>	dB(A) 1 meter (no load)	kg
AMA-B 63K2	0.18	0.87	0.55		2715	0.75	69	110	4	20	18	0.63	5.5	2.2	2.2	67	4
AMA-B 63G2	0.25	1.14	0.66		2715	0.81	68	110	4	20	18	0.88	5.5	2.2	2.2	67	4.5
AMA-B 71K2	0.37	1.64	0.94		2690	0.81	70	110	4	20	18	1.31	6.1	2.2	2.2	71	6
AMA-B 71G2	0.55	2.31	1.33		2715	0.82	73	110	4	20	18	1.93	6.1	2.2	2.3	71	6.5
AMA-B 80K2	0.75	3.02	1.74		2730	0.83	75	110	7.5	20	50	2.62	6.5	2.2	2.3	71	9.6
AMA-B 80G2	1.1	4.27	2.45		2746	0.84	77	110	7.5	20	50	3.83	7.0	2.2	2.3	80	11
AMA-B 90S2	1.5	5.67	3.26		2715	0.84	79	110	15	20	60	5.28	7.0	2.2	2.3	80	14
AMA-B 90L2	2.2	8.02	4.61		2772	0.85	81	110	15	20	60	7.58	7.0	2.2	2.3	80	16
AMA-B 100L2	3	10.43	6.00		2870	0.87	83	110	30	20	80	9.98	7.0	2.2	2.3	85	20
AMA-B 112M2	4		7.72	4.47	2890	0.88	85	186	40	25	110	13.2	7.0	2.0	2.3	85	29
AMA-B 132S2	5.5		10.49	6.08	2910	0.88	86	186	75	25	130	18.0	7.0	2.0	2.3	85	45
AMA-B 132Sx2	7.5		14.14	8.20	2900	0.88	87	186	75	25	130	24.7	7.0	2.0	2.3	86	18
AMA-B 160M2	11		21.3	12.2	2930	0.88	88	186	150	35	130	35.8	7.0	2.0	2.3	90	106
AMA-B 160Mx2	15		28.7	16.4	2930	0.89	89	186	150	35	150	48.9	7.0	2.0	2.2	90	117
AMA-B 160L2	18.5		34.60	19.8	2930	0.90	90	186	150	35	150	63.3	7.0	2.0	2.2	90	130

Frame size	Rated output power	Rated current at			Full-load speed rpm	Full-load power factor	Full-load efficiency	Brake Voltage	Static braking torque	No-load brake response time	Brake power	Full-load torque	Starting current	Starting torque	Pull-out torque	Sound pressure level	Weight foot mounted
		P <sub>N</sub> (KW)	220V I <sub>N</sub> (A)	400V I <sub>N</sub> (A)													
					n <sub>N</sub> (min <sup>-1</sup> )	cos (φ)	100% (η)	V (Vdc)	(Nm)	(ms)	(W)	M <sub>N</sub>	I <sub>S</sub> /I <sub>N</sub>	M <sub>S</sub> /M <sub>N</sub>	M <sub>K</sub> /M <sub>N</sub>	dB(A) 1 meter (no load)	kg
AMA-B 63K4	0.12	0.85	0.49		1350	0.64	53	110	4	20	18	0.85		2.1	2.4	63	3.5
AMA-B 63G4	0.18	1.20	0.70		1340	0.66	56	110	4	20	18	1.28	4.4	2.1	2.4	63	5
AMA-B 71K4	0.25	1.30	0.75		1390	0.74	65	110	4	20	18	1.72	4.4	2.1	2.4	63	6
AMA-B 71G4	0.37	1.85	1.06		1375	0.75	67	110	4	20	18	2.57	5.2	2.1	2.4	68	6.5
AMA-B 80K4	0.55	2.59	1.49		1370	0.75	71	110	7.5	20	50	3.83	6.0	2.4	2.3	68	9.5
AMA-B 80G4	0.75	3.39	1.95		1380	0.76	73	110	7.5	20	50	5.19	6.0	2.3	2.3	68	12
AMA-B 90S4	1.1	4.78	2.75		1390	0.77	75	110	15	20	60	7.56	6.5	2.3	2.3	71	14
AMA-B 90L4	1.5	6.11	3.51		1400	0.79	78	110	15	20	60	10.2	6.5	2.3	2.3	71	16
AMA-B 100L4	2.2	8.52	4.90		1430	0.81	80	110	30	20	80	14.7	7.0	2.2	2.3	71	20
AMA-B 100Lx4	3	11.20	6.44		1430	0.82	82	110	30	20	80	20.0	7.0	2.2	2.3	76	26
AMA-B 112M4	4		8.38	4.86	1430	0.82	84	186	40	25	110	26.7	7.0	2.2	2.3	76	38
AMA-B 132S4	5.5		11.25	6.52	1440	0.83	85	186	75	25	130	36.5	7.0	2.2	2.3	76	46
AMA-B 132M4	7.5		14.81	8.59	1450	0.84	87	186	75	25	130	49.4	7.0	2.2	2.3	81	55
AMA-B 160M4	11		22.30	12.70	1460	0.85	88	186	150	25	150	72.0	7.0	2.2	2.3	90	106
AMA-B 160L4	15		30.00	17.10	1460	0.85	89	186	150	25	150	98.1	7.0	2.2	2.2	90	126

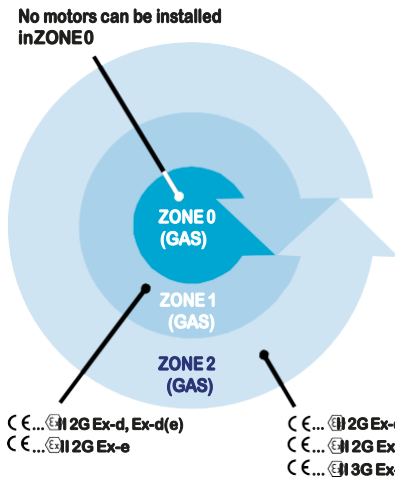

EPL IEC 60067-0		Device category 2014/34/EC		Can be used in zones		Presence of EX atmosphere	Avoidance of sources of ignition
Gas	Dust	Gas	Dust	Gas	Dust		
Gc	Dc	3G	3D	2	22	Rare/brief periods	In normal operation
Gb	Db	2G	2D	1 2	21 22	Occasional	Including with normal malfunctions
Ga	Da	1G	1D	0 1 2	20 21 22	Continuous or frequent	Even with rare malfunctions

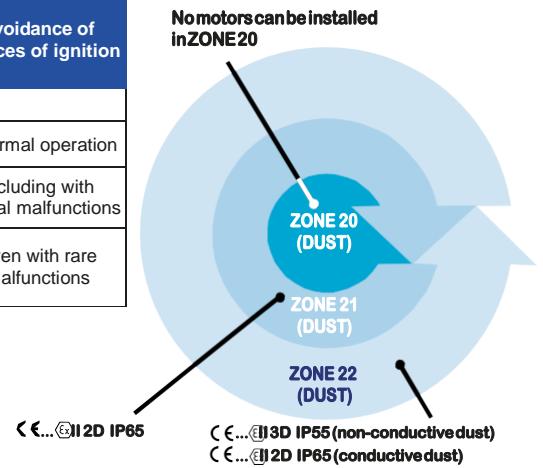

Labelling and categorisation of explosive environment					
Type of material	Frequency of occurrence of flammable material	Categorisation of explosive environment	Labeling of equipment		EPL Equipment protection level
			Equipment group	Device category	
Dusts	Continuously or frequently present	Zone 20	II	1D	Da
	Occasionally present	Zone 21	II	2D	Db
	Rarely present (short periods)	Zone 22	II	3D	Dc
Gas (vapours, mist, etc.)	Continuously or frequently present	Zone 0	II	1G	Ga
	Occasionally present	Zone 1	II	2G	Gb
	Rarely present (short periods)	Zone 2	II	3G	Gc

Explosion group					
Explosion group Dust			Examples		
IIIA	IIIB	IIIC	Flammable fluff		
			Non-conductive dust		
			Conductive dust		
			Maximum surface temperature of equipment in degrees Celsius directly shown (e.g. T125°C)		
Explosion group Gas			Examples (not complete) for gases, depending on explosion group and temperature class		
IIA	IIB	IIC	Acetone, ethane, benzene, methane, propane	Ethyl alcohol, n-butane	Heating oil, petrol and diesel fuels
			Town gas (natural gas)	Ethylene	Hydrogen sulphide
			Hydrogen	Acetylene	
			T1 <450°C		
			T2 <300°C		
			T3 <200°C		
			T4 <135°C		

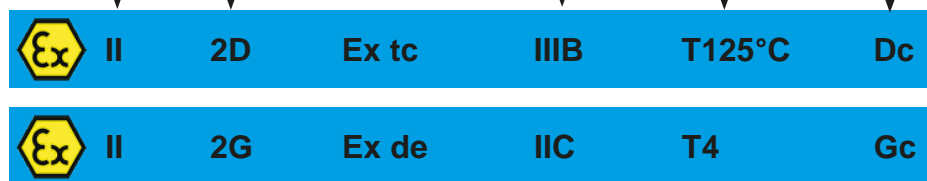

Type of ignition protection for electrical devices				
Protection principle	Type of ignition protection	Identification	Use in zone	Standard
Protection with housing	Dust explosion protection	Ex ta Ex tb Ex tc	20 21 22	EN60079-31
Pressure resistant encapsulation	Contains explosion within motor housing	Ex de or Ex d	1 and 2	EN60079-1
Contains explosion within motor housing	Avoidance of high temperatures and sparks	Ex e	1 and 2	EN60079-7
"Non Sparking"	Non-sparking equipment	Ex na	2	EN60079-15

\*from April 20, 2016 replacement of ATEX 94/9/EC directives with directives according to ATEX 2014/34/EU

We make all efforts to better our products. Versions, technical data and figures could be changed there. They are not binding before written confirmation. 30/01/2019

## IM B3

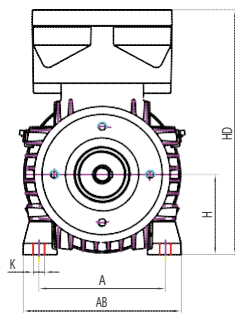
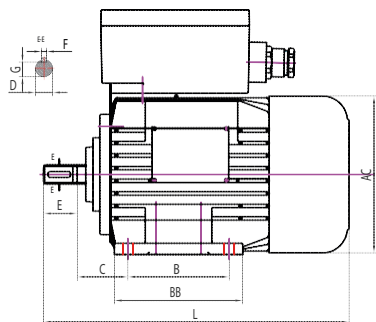

## IM B5

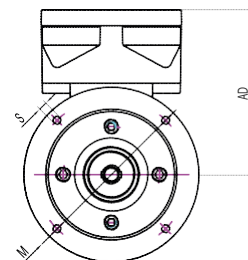
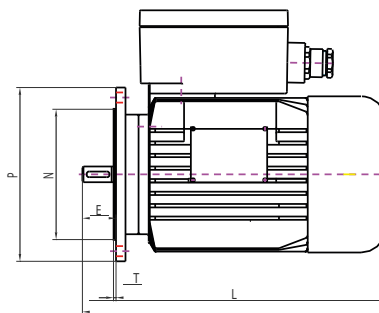

Frame size A B C D E F G H K M N P S T M N P S T AB BB AC AD HD L

	IM B14										IM B5														
<b>71</b>	112	90	45	14	30	5	11	71	7	85	70	105	M6	3.5	130	110	160	9	3.5	140	114	139	218	147	271
<b>80</b>	125	100	50	19	40	6	15.5	80	10	100	80	120	M6	3.5	165	130	200	12	3.5	160	130	157	249	169	317
<b>90</b>	140	125	56	24	50	8	20	90	10	115	95	140	M8	3.5	165	130	200	12	3.5	180	155	177	271	181	360
<b>100L</b>	160	140	63	28	60	8	24	100	12	130	110	160	M8	4	215	180	250	14	4	205	175	195	288	188	416
<b>112M</b>	190	140	70	28	60	8	24	112	12	130	110	160	M8	4	215	180	250	14	4	235	180	219	311	199	438
<b>132S</b>	216	140	89	38	80	10	33	132	12	165	130	200	M10	4	265	230	250	14	4	266	218	258	350	218	534
<b>132M</b>	216	178	89	38	80	10	33	132	12	165	130	200	M10	4	265	230	300	14	4	266	218	258	350	218	534
<b>160L</b>	254	254	108	42	110	12	37	160	14.5						300	250	350	18	5	312	300	310	436	276	667
<b>180M</b>	279	241	121	48	110	14	42.5	180	14.5						300	250	350	18	5	350	333	345	496	316	704
<b>180L</b>	279	279	121	48	110	14	42.5	180	14.5						300	250	350	18	5	350	333	345	496	316	704
<b>200L</b>	318	305	133	55	110	16	49	200	18.5						350	300	400	18	5	398	365	385	546	346	790
<b>225S4-10</b>	356	286	149	60	140	18	53	225	18.5						400	350	450	18	5	436	371	435	589	364	882
<b>225M2</b>	356	311	149	55	110	16	49	225	18.5						400	350	450	18	5	436	371	435	589	364	852
<b>225M4-10</b>	356	311	149	60	140	18	53	225	18.5						400	350	450	18	5	436	371	435	589	364	882

Cast Iron three-phase squirrel cage induction motors according to IEC 34-1, terminal box top mounted. Voltage 220-240/380-420V or 380-420/660-720V, 50Hz, Insulation class F, Protection IP55, Temperature class T1 to T4, Colour RAL 5010, Re-greasable bearings on size 160 and above, Removeable feet upto size 160, Flange motors B14 small available up to and including size 160. B14 large to 132, B35 available on all sizes.

II 2G Ex db IIC T4-T6 Gb or IIC 2G Ex db e IIC T4-T6 Gb and II 2D Ex tb IIIC T135-85°C.  
Certification ATEX and IECEx.



Frame size	Rated output power	Rated current at	Full-load speed rpm	Full-load power factor	Full-load efficiency	Full-load torque	Starting current	Starting torque	Pull-out torque	Moment of inertia	Weight foot mounted
	$P_N$ (KW)	400V $I_N$ (A)	$n_N$ (min <sup>-1</sup> )	cos ( $\varphi$ )	100% ( $\eta$ )	$M_N$	$I / I_N$	$M_s / M_N$	$M_k / M_N$	kgm <sup>2</sup>	kg
4KTC 71 A-2	0.37	0.98	2820	0.81	67.2	1.25	5.4	3	3.2	0.00034	15
4KTC 71 B-2	0.55	1.28	2800	0.86	72.7	1.88	5.4	2.8	3.1	0.00042	16
4KTC 80 A-2	0.75	1.61	2810	0.87	77.5	2.55	4.9	2.6	2.8	0.00063	24
4KTC 80 B-2	1.1	2.29	2775	0.88	78.8	3.78	5.1	2.8	2.9	0.00079	26
4KTC 90 S-2	1.5	3.07	2855	0.86	81.6	5.0	6.1	2.8	3.1	0.00124	32
4KTC 90 L-2	2.2	4.4	2845	0.89	80.8	7.4	5.9	2.7	2.7	0.00155	34
4KTC 100 L-2	3.0	6.4	2875	0.85	79.5	10.0	5.7	3.0	3.3	0.00251	42.5
4KTC 112 M-2	4.0	7.8	2880	0.88	84.0	13.3	6.9	2.7	3.1	0.00451	58
4KTC 132 SA-2	5.5	10.4	2910	0.88	87.0	18.1	6.3	2.6	3.0	0.00967	77
4KTC 132 SB-2	7.5	14.1	2920	0.88	87.7	24.5	6.9	3.0	3.3	0.01225	84
4KTC 160 MA-2	11.0	20.6	2940	0.86	89.4	35.8	7.9	3.8	3.3	0.02943	148
4KTC 160 MB-2	15.0	26.5	2940	0.9	90.6	48.7	7.9	3.4	3.0	0.03912	166
4KTC 160 L-2	18.5	32.2	2945	0.91	91.6	60.0	7.4	3.1	3.1	0.0459	178
4KTC 180 M-2	22.0	41.3	2940	0.91	84.2	71.5	6.9	2.8	2.9	0.06151	205
4KTC 200 LA-2	30.0	54.4	2955	0.9	88.5	97.0	6.9	2.4	2.6	0.10442	240
4KTC 200 LB-2	37.0	66.5	2970	0.91	88.6	119.1	9.0	3.3	3.0	0.12739	250
4KTC 225 M-2	45.0	82.0	2970	0.88	89.6	145.0	7.6	2.5	3.4	0.22155	375

Frame size	Rated output power	Rated current at	Full-load speed rpm	Full-load power factor	Full-load efficiency	Full-load torque	Starting current	Starting torque	Pull-out torque	Moment of inertia	Weight foot mounted
	$P_N$ (KW)	400V $I_N$ (A)	$n_N$ (min <sup>-1</sup> )	cos ( $\varphi$ )	100% ( $\eta$ )	$M_N$	$I / I_N$	$M_s / M_N$	$M_k / M_N$	kgm <sup>2</sup>	kg
4KTC 71 A4	0.25	0.69	1370	0.78	67.0	1.74	3.8	2.15	2.2	0.00051	15
4KTC 71 B4	0.37	0.95	1385	0.78	72.5	2.55	4.0	2.15	2.3	0.00063	16
4KTC 80 A4	0.55	1.34	1400	0.77	76.9	3.76	4.4	2.3	2.4	0.00098	24
4KTC 80 B4	0.75	1.7	1410	0.77	82.4	5.1	5.0	2.6	2.7	0.00125	26
4KTC 90 S4	1.1	2.4	1410	0.82	80.9	7.5	4.8	2.15	2.5	0.00204	32
4KTC 90 L4	1.5	3.35	1415	0.8	80.6	10.1	5.2	2.5	2.8	0.0026	35
4KTC 100 LA4	2.2	4.7	1410	0.82	81.5	14.9	4.6	2.0	2.5	0.00388	42.5
4KTC 100 LB4	3.0	6.5	1415	0.83	79.6	20.2	5.0	2.1	2.6	0.00499	46
4KTC 112 M4	4.0	8.3	1435	0.81	85.4	26.6	6.1	2.8	3.1	0.01014	60
4KTC 132 S4	5.5	10.8	1435	0.85	86.0	36.6	5.1	2.2	2.4	0.02113	84
4KTC 132 M4	7.5	14.5	1445	0.84	88.9	49.5	6.0	2.5	2.8	0.02793	93.5
4KTC 160 M4	11.0	22.0	1460	0.83	87.1	71.8	6.9	2.9	3.1	0.05417	159
4KTC 160 L4	15.0	29.0	1465	0.83	90.8	97.8	7.4	3.1	3.0	0.07116	178
4KTC 180 M4	18.5	35.0	1465	0.86	89.9	120.6	6.9	3.1	2.5	0.1129	215
4KTC 180 L4	22.0	40.5	1470	0.86	90.9	143.2	7.1	3.1	2.6	0.1339	236
4KTC 200 L4	30.0	53.4	1470	0.91	89.6	195.1	6.8	2.7	2.8	0.21298	250
4KTC 225 S4	37.0	66.6	1475	0.87	92.2	239.7	7.0	2.9	2.4	0.36225	310
4KTC 225 M4	45.0	80.5	1475	0.87	92.5	291.0	7.3	3.3	2.7	0.42845	390

Frame size	Rated output power	Rated current at	Full-load speed rpm	Full-load power factor	Full-load efficiency	Full-load torque	Starting current	Starting torque	Pull-out torque	Moment of inertia	Weight foot mounted
	P <sub>N</sub> (KW)	400V I <sub>N</sub> (A)	n <sub>N</sub> (min <sup>-1</sup> )	cos (φ)	100% (η)	M <sub>N</sub>	I <sub>s</sub> /I <sub>N</sub>	M <sub>s</sub> /M <sub>N</sub>	M <sub>k</sub> /M <sub>N</sub>	kgm <sup>2</sup>	kg
4KTC 71 A6	0.18	0.67	930	0.65	60.0	1.86	3.1	2.1	2.3	0.00081	15
4KTC 71 B6	0.25	0.85	940	0.67	64.0	2.56	3.7	2.2	2.5	0.00101	16
4KTC 80 A6	0.37	1.1	925	0.72	67.0	3.83	3.6	2.3	2.5	0.00191	25
4KTC 80 B6	0.55	1.5	915	0.74	72.0	5.7	4.1	2.35	2.5	0.00239	26.5
4KTC 90 S6	0.75	2.1	915	0.74	70.0	7.8	3.7	1.8	2.1	0.00323	32
4KTC 90 L6	1.1	3.0	915	0.73	73.0	11.5	4.1	2.1	2.3	0.00419	35
4KTC 100 L6	1.5	3.7	930	0.77	76.0	15.4	4.7	2.2	2.3	0.00657	46
4KTC 112 M6	2.2	5.0	960	0.78	82.0	21.9	6.1	2.6	2.7	0.0158	60
4KTC 132 S6	3.0	6.6	975	0.79	83.5	29.4	6.3	2.3	2.5	0.02722	84
4KTC 132 MA6	4.0	8.8	960	0.8	83.0	39.9	6.3	2.4	2.9	0.03229	88
4KTC 132 MB6	5.5	11.8	955	0.81	83.5	55.1	6.1	2.3	2.9	0.03838	95
4KTC 160 M6	7.5	15.8	970	0.8	86.0	74.2	6.7	2.7	2.4	0.8121	161
4KTC 160 L6	11.0	23.5	965	0.77	88.5	109.0	6.0	2.2	2.3	0.10916	182
4KTC 180 L6	15.0	31.0	965	0.78	89.5	148.0	5.2	1.9	2.3	0.227	236
4KTC 200 LA6	18.5	36.0	965	0.81	91.0	183.0	6.0	1.9	2.4	0.24369	240
4KTC 200 LB6	22.0	43.0	965	0.81	91.5	218.6	6.0	1.9	2.4	0.27888	250
4KTC 225 M6	30.0	56.0	975	0.83	92.5	293.0	5.8	1.8	2.5	0.66117	390

## 4KTC Terminal box and terminals cable entry

Frame size	Terminals	Cable entries for main connection EEx d(e) terminal box	
		For max. cross section of supply cable (mm <sup>2</sup> )	External diameter of supply cable (mm)
71	2.5	1 x M20 x 1.5	6.5 to 12
80	4	1 x M25 x 1.5	13 to 18
90	4	1 x M25 x 1.5	13 to 18
100	4	1 x M25 x 1.5	13 to 18
112	4	1 x M32 x 1.5	13 to 18
132	4	2 x M32 x 1.5	13 to 18
160	16	2 x M40 x 1.5	22 to 32
180	16	2 x M40 x 1.5	22 to 32
200	16	2 x M50 x 1.5	32 to 38
225	16	2 x M50 x 1.5	32 to 38
250	95-300	2 x M63 x 1.5	37 to 44
280	95-300	2 x M63 x 1.5	37 to 44
315	95-300	2 x M63 x 1.5	37 to 44

### IM B3

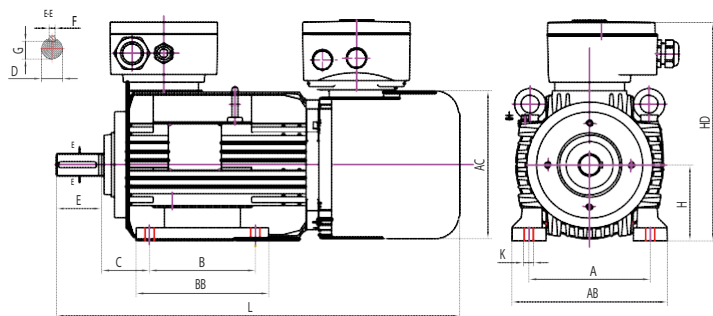

### IM B5

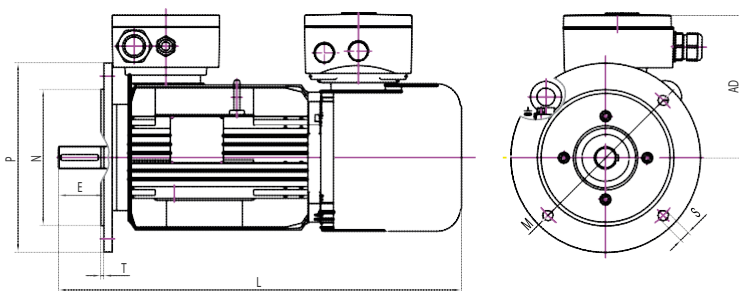

Frame size	A	B	C	D	E	F	G	H	K	M	N	P	S	T	M	N	P	S	T	AB	BB	AC	AD	HD	L
	<b>IM B14</b>										<b>IM B5</b>														
<b>71 (08)</b>	112	90	45	14	30	5	16	71	9	85	70	105	M6	2.5	130	110	160	9	3.5	140	114	218	10	366	271
<b>80 (10)</b>	125	100	50	19	40	6	21.5	80	10	100	80	120	M6	3	165	130	200	12	3.5	160	130	249	10	428	317
<b>90 (13)</b>	140	125	56	24	50	8	27	90	10	115	95	140	M8	3	165	130	200	12	3.5	180	155	271	10	472	360
<b>100L (15)</b>	160	140	63	28	60	8	31	100	12	130	110	160	M8	3.5	215	180	250	14	4	205	175	288	11	543	416
<b>112M (17)</b>	190	140	70	28	60	8	31	112	12	130	110	160	M8	3.5	215	180	250	14	4	235	180	311	11	563	438
<b>132S (20)</b>	216	140	89	38	80	10	41	132	12						265	230	300	14	4	266	218	350	15	666	534
<b>132M (20)</b>	216	178	89	38	80	10	41	132	12						265	230	300	14	4	266	218	350	15	666	534

Cast Iron three-phase Flameproof squirrel cage induction brake motors according to IEC 34-1, terminal box top mounted. Voltage 220-240/380-420V or 380-420/660-720V, 50Hz, Insulation class F, Protection IP55, Temperature class T1 to T4, Colour RAL 5010, Removeable feet, Flange motors B14 small and large, B35 available on all sizes. II 2G Ex db IIC T4-T6 Gb or IIC 2G Ex db e IIC T4-T6 Gb and II 2D Ex tb IIIC T135-85°C. Certification ATEX and IECEx.

# 4KTC Ex db IIC Brake motor : 2 - Pole - 3000 min<sup>-1</sup> *AMTECS*

Frame size	Torque Nm		Voltage AC	Power (1 Phase)	Maximum RPM		Starts per hour	Breaking time	Weight (kg)		
	min.	max.			S1	S9			B3	B5	B14
BM 4KTC 71 A-2/08	5	6.5	230	22	2800	5600	2900	90	27	29	28
BM 4KTC 71 B-2/08	5	6.5	230	22	2800	5600	2450	90	27	29	28
BM 4KTC 80 A-2/10	10	13	230	28	2780	5560	1900	145	37	39	38
BM 4KTC 80 B-2/10	10	13	230	28	2800	5600	160	145	37	39	38
BM 4KTC 90 S-2/13	20	26	230	34	2840	5680	1200	280	49	51	50
BM 4KTC 90 L-2/13	20	26	230	34	2820	5640	1050	280	49	51	50
BM 4KTC 100 L-2/15	40	52	230	42	2820	5640	630	225	63	67	66
BM 4KTC 112 M-2/17	60	78	230	50	2840	5680	270	290	81	87	86
BM 4KTC 132 SA-2/20	100	130	230	76	2860	5720	250	420	126	132	131
BM 4KTC 132 SB-2/20	100	130	230	76	2860	5720	250	420	126	132	131

# 4KTC Ex db IIC Brake motor : 4 - Pole - 1500 min<sup>-1</sup> *AMTECS*

Frame size	Torque Nm		Voltage AC	Power (1 Phase)	Maximum RPM		Starts per hour	Breaking time	Weight (kg)		
	min.	max.			S1	S9			B3	B5	B14
BM 4KTC 71 A-4/08	5	6.5	230	22	1400	2800	7200	90	27	29	28
BM 4KTC 71 B-4/08	5	6.5	230	22	1380	2760	5500	90	27	29	28
BM 4KTC 80 A-4/10	10	13	230	28	1400	2800	3700	145	37	39	38
BM 4KTC 80 B-4/10	10	13	230	28	1400	2800	4200	145	37	39	38
BM 4KTC 90 S-4/13	20	26	230	34	1400	2800	2300	280	49	51	50
BM 4KTC 90 L-4/13	20	26	230	34	1410	2820	2700	280	49	51	50
BM 4KTC 100 LA-4/15	40	52	230	42	1420	2840	1200	225	63	67	66
BM 4KTC 100 LB-4/15	40	52	230	42	1420	2840	1600	225	63	67	66
BM 4KTC 112 M-4/17	60	78	230	50	1430	2860	1100	290	81	87	86
BM 4KTC 132 SA-4/20	100	130	230	76	1440	2880	900	420	126	132	131
BM 4KTC 132 SB-4/20	100	130	230	76	1440	2880	400	420	126	132	131

# 4KTS IP68 Ex db e IIB T4 Zone 1: 4 - Pole - 1500 min<sup>-1</sup> *AMTECS*

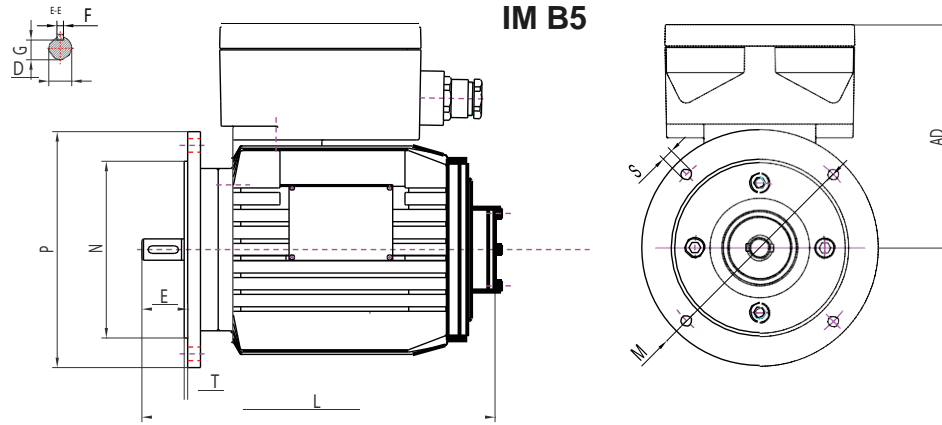

Frame size	D	E	F	G	H	M	N	P	S	T	LC	L
<b>90</b>	24	50	8	20	90	165	130	200	12	3.5	10	323
<b>100L</b>	28	60	8	24	100	215	180	250	14	4	11	359
<b>112M</b>	28	60	8	24	112	215	180	250	14	4	11	378
<b>132M</b>	38	80	10	33	132	265	230	300	14	4	12	469
<b>160L</b>	42	110	12	37	160	300	250	350	18	5	14	604
<b>180M</b>	48	110	14	42.5	180	300	250	350	18	5	14	627
<b>132M</b>	38	80	10	33	132	265	230	300	14	4	266	218
<b>160L</b>	42	110	12	37	160	300	250	350	18	5	312	300
<b>180M</b>	48	110	14	42.5	180	300	250	350	18	5	350	333
<b>180L</b>	48	110	14	42.5	180	300	250	350	18	5	350	333
<b>200L</b>	55	110	16	49	200	350	300	400	18	5	398	365

Cast Iron three-phase Flameproof squirrel cage induction motors. Motor suitable for continuous running in air and upto 12 meters under water. Totally enclosed, non ventilated. Voltage 220-240/380-420V or 380-420/660-720V, 50Hz, Insulation class F, Protection IP68, Thermal overload protection PTC, Colour RAL 5010, Motors are B5 flange mounted as standard, Flanges B14 small, large, and B35 available by request.  
 II 2G Ex db e IIB T4 Gb or IIC 2G Ex db e IIB T4 Gb.  
 Certification ATEX and IECEx.

# 4KTS IP68 Ex db e IIB T4 Zone 1: 4 - Pole - 1500 min<sup>-1</sup> *AMTECS*

Frame size	Rated output power	Voltage	Full-load Current	Full-load speed rpm	Full-load power factor	Full-load efficiency	Full-load torque	Starting current	Starting torque	Pull-out torque
	$P_N$ (KW)	(V)	$I_N$ (A)	$n_N$ (min <sup>-1</sup> )	cos (φ)	100% (η)	$M_N$	$I_s/I_N$	$M_s/M_N$	$M_k/M_N$
<b>4KTS 90L-4</b>	0.75	380	1.77	1423	0.829	77.6	5.04	6.01	2.60	
		400	1.696	1433	0.801	79.6	5.01	6.60	2.90	
		415	1.687	1438	0.778	79.5	4.99	6.89	3.14	
		380	1.63	1426	0.812	86.3	5.02	6.28	2.52	2.87
		400	1.59	1435	0.783	87.2	4.99	6.78	2.81	3.20
		415	1.57	1441	0.758	87.5	4.97	7.12	3.03	3.46
<b>4KTS 100LB-4</b>	1.5	380								
		400	3.18	1438	0.83	82	9.96	6.14	2.48	
		415								
		380	3.28	1416	0.844	82.3	10.11	5.69	2.16	2.60
		400	3.16	1422	0.828	82.6	10.07	6.23	2.41	2.88
		415	3.11	1434	0.803	83.6	9.99	6.56	2.61	3.14
<b>4KTS 132S-4</b>	2.2	380	4.65	1448	0.865	83	14.54	5.78	2.35	
		400	4.45	1455	0.852	83.7	14.46	6.36	2.62	
		415	4.32	1458	0.841	84.3	14.43	6.79	2.82	
		380	4.72	1440	0.862	82.1	14.58	5.60	2.29	2.45
		400	4.5	1447	0.85	82.8	14.51	6.20	2.56	2.74
		415	4.38	1452	0.839	83.4	14.47	6.59	2.75	2.95
<b>4KTS 160M-4</b>	3.7	380	7.6	1466	0.86	86	24.09	6.50	2.67	2.68
		400	7.26	1471	0.849	86.5	24.02	7.16	2.97	2.98
		415	7.01	1472	0.842	87.1	23.99	7.70	3.20	3.21
<b>4KTS 160M-4</b>	4	380	8.04	1468	0.861	87.7	26.01	6.43	2.55	2.50
		400	7.66	1472	0.853	88.2	25.94	7.10	2.83	2.78
		415	7.49	1474	0.845	87.9	25.91	7.20	3.04	2.99
<b>4KTS 180M-4</b>	7.5	380	17.4	1486	0.734	89.3	48.2	11.02	5.68	5.40
		400	17.77	1487	0.687	88.8	48.13	11.29	6.32	6.01
		415	18.47	1488	0.648	87.2	48.12	11.36	6.82	6.47
<b>4KTS 180M-4</b>	7.5	380	15.1	1465	0.87	86.9	48.9	6.39	2.29	2.60
		400	14.5	1468	0.86	87	48.8	7.01	2.55	2.90
		415	14.1	1470	0.85	87.1	48.75	7.49	2.76	3.13



# AMAS-R (Cap Run) 1 Phase

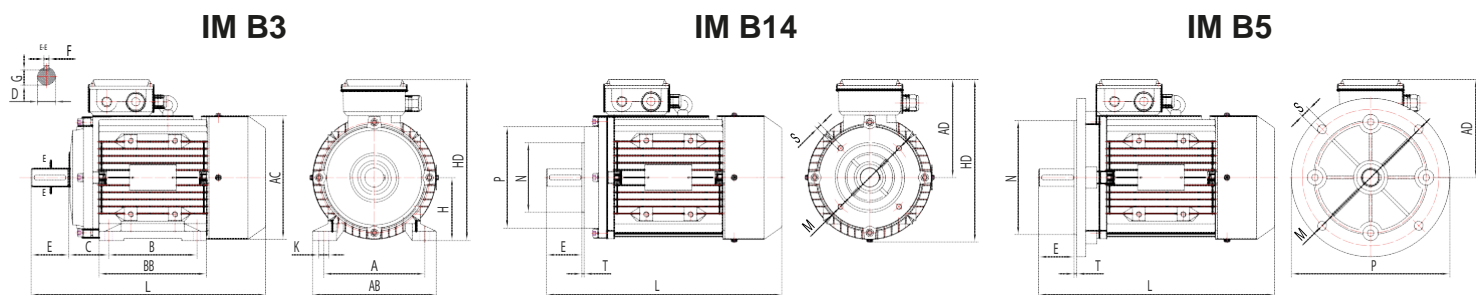

Frame size	A	B	C	D	E	F	G	H	K	M	N	P	S	T	M	N	P	S	T	M	N	P	S	T	AB	BB	AC	AD	HD	L
	<b>IM B14</b>										<b>IM B14L</b>					<b>IM B5</b>														
<b>63</b>	100	80	40	11	23	4	8.5	63	7	75	60	90	M5	2.5	115	95	140	10	3.0	125	103	120	122	185	215	89	110	100	156	195
<b>71</b>	112	90	45	14	30	5	11	71	7	85	70	105	M6	2.5	130	110	160	10	3.5	138	113	140	135	205	245	103	120	109	172	213
<b>80</b>	125	100	50	19	40	6	15.5	80	10	100	80	120	M6	3	165	130	200	12	3.5	159	122	158	145	225	285	104	139	119	189	255
<b>90S</b>	140	100/125*	56	24	50	8	20	90	10	115	95	140	M8	3	165	130	200	12	3.5	175	155	175	150	240	330	124	158	135	215	285
<b>90L</b>	140	100/125*	56	24	50	8	20	90	10	115	95	140	M8	3	165	130	200	12	3.5	175	155	175	150	240	330	125	175	145	235	308
<b>100L</b>	160	140	63	28	60	8	24	100	215	130	110	160	M8	3.5	100	215	250	15	4	205	176	196	165	265	375	150	175	145	235	329

Aluminium three-phase squirrel cage induction single phase with running capacitor motors according to IEC/DIN, multi-mount design with removable feet, Black plastic ABS terminal boxes house the run capacitor, High running torque  $M_s \Rightarrow$  60-70%, Voltage 220-240V, 50Hz, Insulation class F, Class B Temperature rise, Protection IP55, Colour RAL 5010. NSK Bearing and Cast iron drive end shield frame 100 and above.

Flange motors B5, B14 small and large available on all sizes.

\*Feet have mounting holes for both s and L

# AMAS-R (Cap Run) 2 & 4 Pole

Frame size	Rated output power	Rated current at	Run Capacitor	Full-load speed rpm	Full-load power factor	Full-load efficiency	Full-load torque	Starting current	Starting torque	Pull-out torque	Sound pressure level	Weight foot mounted
	$P_N$ (KW)	230V $I_N$ (A)	$\mu\text{F/V}$	$n_n$ ( $\text{min}^{-1}$ )	$\cos(\varphi)$	100% ( $\eta$ )	$M_N$	$I / I_{S N}$	$M_s / M_N$	$M_k / M_N$	dB(A) 1 meter (no load)	kg
AMAS-R 63K2	0.18	1.48	8 $\mu\text{f}/450\text{V}$	2800	0.92	60	0.63	5	0.40	1.7	70	3.9
AMAS-R 63G2	0.25	1.96	12 $\mu\text{f}/450\text{V}$	2800	0.92	63	0.87	7	0.40	1.7	70	4.4
AMAS-R 71K2	0.37	2.73	16 $\mu\text{f}/450\text{V}$	2800	0.92	67	1.29	10	0.35	1.7	75	6.2
AMAS-R 71G2	0.55	3.88	20 $\mu\text{f}/450\text{V}$	2800	0.92	70	1.95	15	0.35	1.7	75	6.5
AMAS-R 80K2	0.75	5.15	25 $\mu\text{f}/450\text{V}$	2800	0.92	72	2.58	20	0.33	1.7	75	8.3
AMAS-R 80G2	1.10	7.02	30 $\mu\text{f}/450\text{V}$	2800	0.95	75	3.66	30	0.33	1.7	78	11
AMAS-R 90S2	1.50	9.44	40 $\mu\text{f}/450\text{V}$	2800	0.95	76	5.13	45	0.3	1.7	83	15
AMAS-R 90L2	2.20	13.67	60 $\mu\text{f}/450\text{V}$	2800	0.95	77	7.52	65	0.3	1.7	83	17
AMAS-R 63K4	0.12	1.10	10 $\mu\text{f}/450\text{V}$	1400	0.92	55	0.87	3.5	0.4	1.7	65	4
AMAS-R 63G4	0.18	1.62	10 $\mu\text{f}/450\text{V}$	1400	0.92	56	1.27	5	0.4	1.7	65	4.7
AMAS-R 71K4	0.25	2.02	14 $\mu\text{f}/450\text{V}$	1400	0.92	61	1.75	7	0.35	1.7	65	6.3
AMAS-R 71G4	0.37	2.95	20 $\mu\text{f}/450\text{V}$	1400	0.92	62	2.60	10	0.35	1.7	70	7
AMAS-R 80K4	0.55	4.25	25 $\mu\text{f}/450\text{V}$	1400	0.92	64	3.75	15	0.35	1.7	70	9.5
AMAS-R 80G4	0.75	5.45	35 $\mu\text{f}/450\text{V}$	1400	0.92	68	5.11	20	0.32	1.7	70	11.6
AMAS-R 90S4	1.10	7.45	45 $\mu\text{f}/450\text{V}$	1400	0.95	71	7.58	30	0.32	1.7	73	14
AMAS-R 90L4	1.50	9.83	60 $\mu\text{f}/450\text{V}$	1400	0.95	73	10.29	45	0.3	1.7	78	17
AMAS-R 100L4	2.20	11.7	90 $\mu\text{f}/450\text{V}$	1400	0.98	83	15.13	56.7	0.3	1.9	86	23

# AMAS-SR (Cap Start/Cap Run) 1 Phase

AMTECS

IM B3

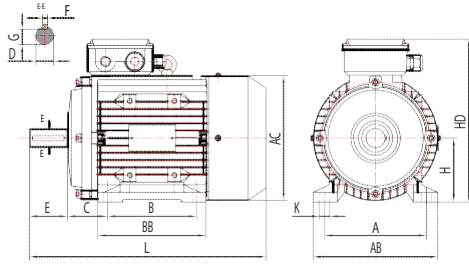

IM B14

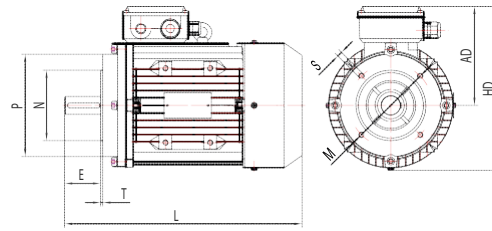

IM B5

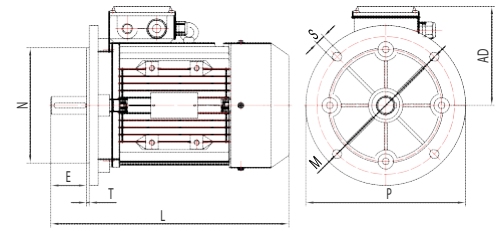

Frame size	A	B	C	D	E	F	G	H	K	M	N	P	S	T	M	N	P	S	T	M	N	P	S	T	AB	BB	AC	AD	HD	L
											<b>IM B14</b>					<b>IM B14L</b>					<b>IM B5</b>									
<b>71</b>	112	90	45	14	30	5	11	71	7	85	70	105	M6	2.5	130	110	160	10	3.5	138	113	140	135	205	250	89	110	100	156	195
<b>80</b>	125	100	50	19	40	6	15.5	80	10	100	80	120	M6	3.0	165	130	200	12	3.5	159	122	158	145	225	301	103	120	109	172	213
<b>90S</b>	140	100	56	24	50	8	20	90	10	115	95	140	M8	3.0	165	130	200	12	3.5	175	155	175	155	240	334	104	139	119	189	255
<b>90L</b>	140	125	56	24	50	8	20	90	10	115	95	140	M8	3.0	165	130	200	12	3.5	175	155	175	165	245	360	124	158	135	215	285
<b>100L</b>	160	140	63	28	60	8	24	100	12	130	110	160	M8	3.5	215	180	250	15	4.0	205	176	196	165	265	401	125	175	145	235	308
<b>112M</b>	190	140	70	28	60	8	24	112	12	130	110	160	M8	3.5	215	180	250	15	4.0	222	180	220	180	292	442	150	175	145	235	329

Aluminium three-phase squirrel cage induction single phase with starting and running capacitor motors according to IEC/DIN, multi-mount design with removable feet, Black plastic ABS terminal boxes house the both the start and run capacitor, centrifugal mechanical switch design, high starting & running torque  $M \Rightarrow 180\%$ .

Voltage 220-240V, 50Hz, Insulation class F, Class B Temperature rise, Protection IP55, Colour RAL 5010. NSK Bearing and Cast iron drive end shield frame 100 and above.

Flange motors B5, B14 small and large available on all sizes.

\*Feet have mounting holes for both s and L

# AMAS-SR (Cap Start/Cap Run) : 2 & 4 - Pole

AMTECS

Frame size	Rated output power	Rated current at	Start Capacitor	Run Capacitor	Full-load speed rpm	Full-load power factor	Full-load efficiency	Full-load torque	Starting current	Starting torque	Pull-out torque	Sound pressure level	Weight foot mounted
	$P_N$ (KW)	230V $I_N$ (A)	$\mu\text{f/V}$	$\mu\text{f/V}$	$n_N$ (min <sup>-1</sup> )	cos ( $\phi$ )	100% ( $\eta$ )	$M_N$	$I_s/I_N$	$M_s/M_N$	$M_k/M_N$	dB(A) 1 meter (no load)	kg
AMAS-SR 71K2	0.37	2.73	75 $\mu\text{f}/300\text{V}$	16 $\mu\text{f}/450\text{V}$	2800	0.92	67	0.129	16	2.3	1.8	72	6
AMAS-SR 71G2	0.55	3.88	100 $\mu\text{f}/300\text{V}$	20 $\mu\text{f}/450\text{V}$	2800	0.92	70	0.194	21	2.5	1.8	72	7
AMAS-SR 80K2	0.75	5.15	100 $\mu\text{f}/300\text{V}$	25 $\mu\text{f}/450\text{V}$	2800	0.92	72	0.260	30	2.5	1.8	75	10
AMAS-SR 80G2	1.10	7.02	150 $\mu\text{f}/300\text{V}$	30 $\mu\text{f}/450\text{V}$	2800	0.95	75	0.381	40	2.5	1.8	75	11
AMAS-SR 90S2	1.50	9.44	200 $\mu\text{f}/300\text{V}$	40 $\mu\text{f}/450\text{V}$	2800	0.95	76	0.522	55	2.5	1.8	78	14
AMAS-SR 90L2	2.20	13.67	300 $\mu\text{f}/300\text{V}$	60 $\mu\text{f}/450\text{V}$	2800	0.95	77	0.744	80	2.5	1.8	78	19
AMAS-SR 100L2	3.00	18.2	400 $\mu\text{f}/300\text{V}$	60 $\mu\text{f}/450\text{V}$	2800	0.95	79	1.044	110	2.5	1.8	91	23
AMAS-SR 112M2	3.70	22.85	600 $\mu\text{f}/300\text{V}$	50 $\mu\text{f}/450\text{V}$	2800	0.946	80	1.353	133	2.5	1.8	91	40
AMAS-SR 71K4	0.25	1.99	50 $\mu\text{f}/300\text{V}$	10 $\mu\text{f}/450\text{V}$	1400	0.92	62	0.174	12	2.5	1.8	67	6.4
AMAS-SR 71G4	0.37	2.81	75 $\mu\text{f}/300\text{V}$	14 $\mu\text{f}/450\text{V}$	1400	0.92	65	0.261	16	2.5	1.8	67	7
AMAS-SR 80K4	0.55	4.0	100 $\mu\text{f}/300\text{V}$	25 $\mu\text{f}/450\text{V}$	1400	0.92	68	0.383	21	2.5	1.8	70	10
AMAS-SR 80G4	0.75	5.22	150 $\mu\text{f}/300\text{V}$	30 $\mu\text{f}/450\text{V}$	1400	0.92	71	0.522	30	2.5	1.8	70	11.5
AMAS-SR 90S4	1.10	7.2	150 $\mu\text{f}/300\text{V}$	30 $\mu\text{f}/450\text{V}$	1400	0.95	73	0.766	40	2.5	1.8	73	15
AMAS-SR 90L4	1.50	9.57	200 $\mu\text{f}/300\text{V}$	40 $\mu\text{f}/450\text{V}$	1400	0.95	75	1.044	55	2.5	1.8	73	17
AMAS-SR 100L4	2.20	13.9	300 $\mu\text{f}/300\text{V}$	60 $\mu\text{f}/450\text{V}$	1400	0.95	76	1.531	60	2.5	1.8	86	23
AMAS-SR 100LX4	3.00	17.1	400 $\mu\text{f}/300\text{V}$	60 $\mu\text{f}/450\text{V}$	1400	0.96	78	2.088	70	2.5	1.8	86	30
AMAS-SR 112M4	3.70	22.01	600 $\mu\text{f}/300\text{V}$	50 $\mu\text{f}/450\text{V}$	1400	0.90	81	2.504	101	2.4	1.8	91	43

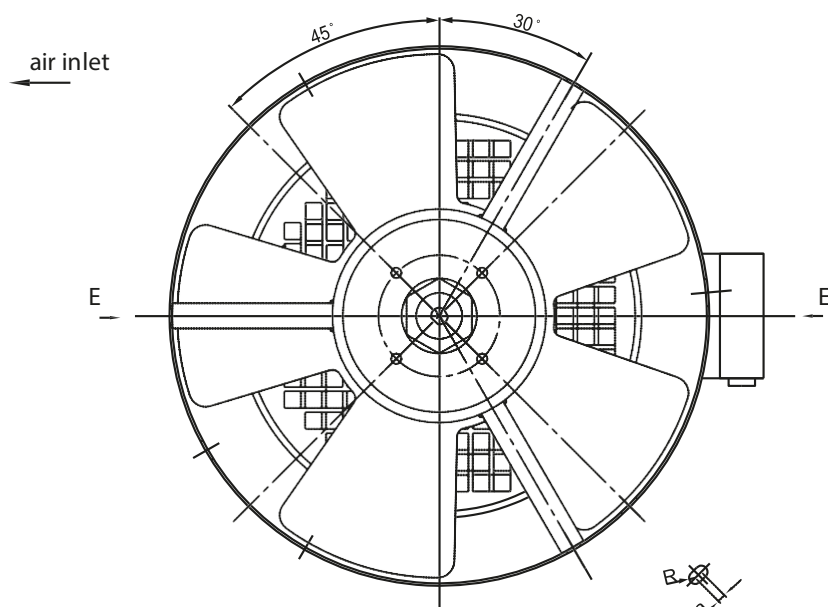
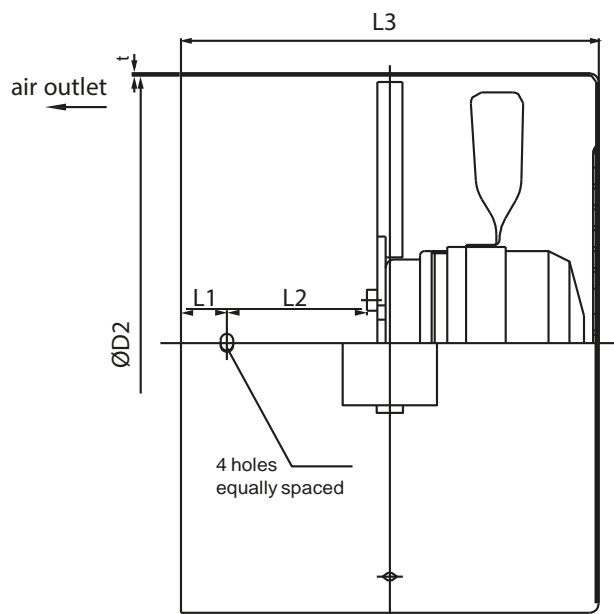

Frame size	D2	L1	L2	L3	t	a	R	Voltage	Power (W)	Speed (min <sup>-1</sup> )	Air flow (m <sup>3</sup> /h)	Air pressure (Pa)
<b>63</b>	118	15	45	130	1.2	1.5	2.25	230V or 230/400V	16	2800	200	50
<b>71</b>	137	15	55	147	1.2	1.5	2.25	230V or 230/400V	18	2800	250	50
<b>80</b>	157	12	75	197	1.5	1.5	2.25	230V or 230/400V	20	2800	350	60
<b>90</b>	174	12	75	202	1.5	1.5	2.25	230V or 230/400V	22	2800	500	80
<b>100</b>	197	22	80	217	1.5	4.5	2.75	230V or 230/400V	30	2800	650	80
<b>112</b>	217	18	90	223	1.5	4.5	2.75	230/400V	35	2800	980	100
<b>132</b>	256	25	150	395	1.5	4.5	2.75	230/400V	90	1400	880	70
<b>160</b>	311	20	142	336	2	5	3.5	230/400V	90	1400	609	40
<b>180</b>	352	40	170	427	2	5	3.5	230/400V	180	1400	686	55
<b>200</b>	394	40	170	461	2	6	4.5	230/400V	250	1400	1679	65
<b>225</b>	442	45	185	466	2	6	4.5	230/400V	250	1400	1786	70
<b>250</b>	481	55	190	483	2	6	4.5	230/400V	370	1400	1813	80
<b>280</b>	543	64	201	542	2	9	5.5	230/400V	550	1400	2415	85
<b>315</b>	616	75	270	620	2	13	6	230/400V	750	1400	2820	110
<b>355</b>	694	114	266	700	2	13	6	230/400V	1100	1400	4000	110

Force air ventilation units suitable for the AmTecs range of Cast Iron and Aluminium motors, Available in single phase 230V 50Hz for size 63 to 100 and 220-240/380-420V or 380-420/660-720V, 50Hz three phase for all sizes. Colour RAL 5010.

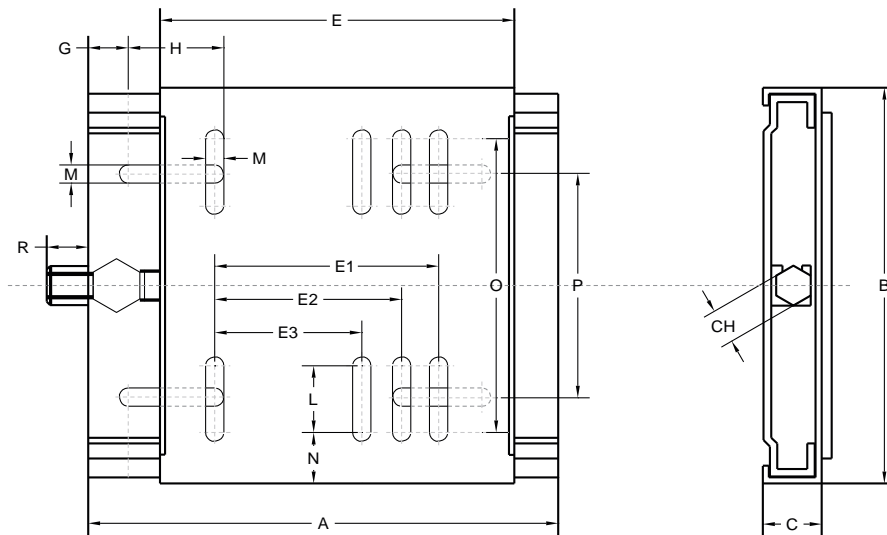

Type	Frame size	A	B	C	Ch	E	E3	E2	E1	G	H	L	M	N	O	P	R	Weight (kg)
SPB 90/112	90-100-112	307	213	33	19	255	140	160	190	28	50	50	10.5	25.5	162	108	30	4.1
SPB 100/132-2	100-112-132	340	290	40	22	286	160	190	216	28	63	47.5	12.5	37.5	215	165	30	7.9
SPB 100/132	100-112-132	430	290	40	22	286	160	190	216	28	63	47.5	12.5	37.5	215	165	30	8.9
SPB 160/180-2	160-180	430	370	40	22	380		254	279	30	62	62	12.5	41.5	287	248	30	12
SPB 160/180	160-180	490	370	40	22	380		254	279	30	62	62	12.5	41.5	287	248	30	12.7
SPB 180/200	160-180	490	410	40	22	418		279	318	30	60	60	17	40.5	389	285	30	14.9
SPB 200/225	200-225	585	450	50	22	468		318	356	30	60	60	17	49	352	300	30	23.7
SPB 250*	250	600	470	65	22	515			406	30	60	60	22	50.5	369	320	30	28.1
SPB 280*	280	735	570	65	22	585			457	30	70	70	22	55	460	420	30	38.2

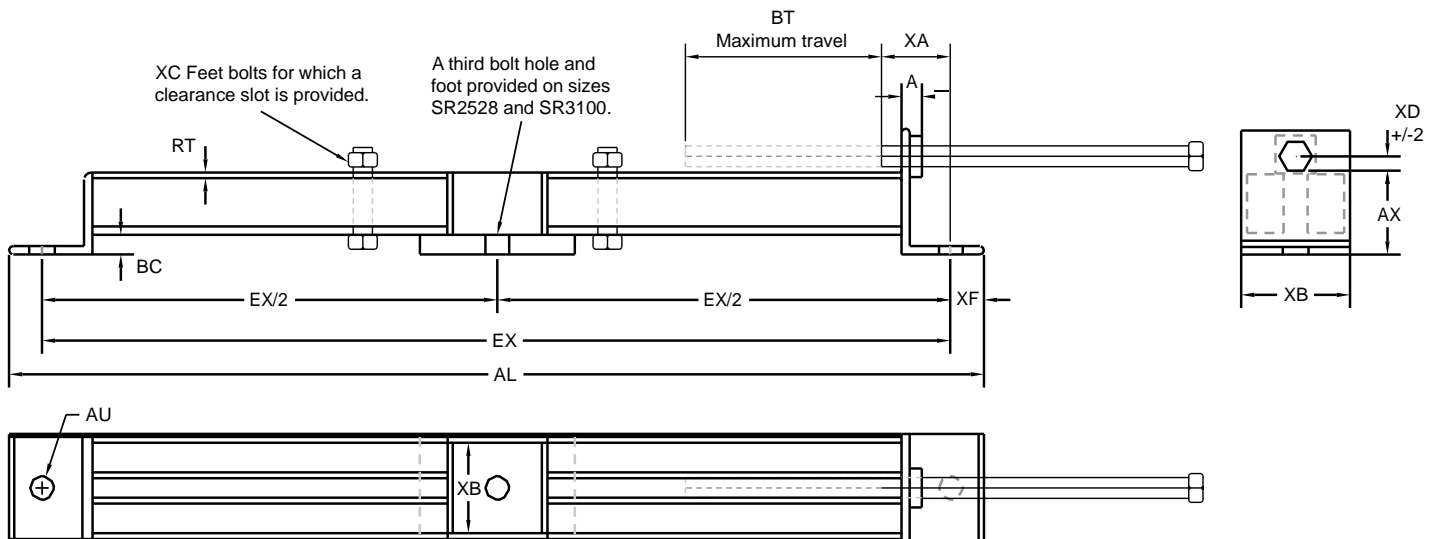

Type	AL	A	AU	AX	BC	XF	XA	XB	RT	XD	XE	Bolt Size	Frame Size	BT	XC Motor Foot Bolts
SR0809	355	8	10	30	10	15	35	30	2	6	325	M10x130	63/71	90	M8x40
SR0809	355	8	10	30	10	15	35	30	2	6	325	M10x130	80	95	M8x40
SR0809	355	8	10	30	10	15	35	30	2	6	325	M10x200	90	80	M8x40
SR1013	470	10	12	44	12	20	36	45	3	6	430	M10x200	100	171	M10x60
SR1013	470	10	12	44	12	20	36	45	3	6	430	M10x200	112	137	M10x60
SR1013	470	10	12	44	12	20	36	45	3	6	430	M12x220	132	106	M10x60
SR1618	615	12	15	64	14	25	52	57	3.15	12	565	M12x220	160	160	M12x80
SR1618	615	12	15	64	14	25	52	57	3.15	12	565	M16x270	180	125	M12x80
SR2022	785	16	19	82	16	30	80	82	4	12	725	M16x270	200	210	M16x110
SR2022	785	16	19	82	16	30	80	82	4	12	725	M16x270	225	140	M16x110
SR2528	945	20	24	82	20	30	58	102	3.2 Box Section	16	885	M20x300	250	250	M20x130
SR2528	945	20	24	82	20	30	58	102		16	885	M20x300	280	190	M20x130
SR3100	1215	25	28	100	15	50	70	102	75x38 Channel	20	1115	M24c375	315	330	M24x150
SR3100	1215	25	28	100	15	50	70	102		20	1115	M24x375	355	330	M24x150

Size	Motor Frame	N		M		P	5	7.5	10	15	20	25	30	40	50	60	80	100	
		B5	B14	B5	B15	B5	B14												
030	56B5/B14	80	50	100	65	120	80	9	9	9	9	9	9	9	9	9	9	9	-
	63B5/B14	95	60	115	75	140	90	11	11	11	11	11	11	11	11	11	-	-	-
040	56B5	80	-	100	-	120	-	-	-	-	-	-	-	-	9	9	9	9	-
	63B5/B14	95	60	115	75	140	90	11	11	11	11	11	11	11	11	11	11	11	11
	71B5/B14	110	70	130	85	160	105	14	14	14	14	14	14	14	14	-	-	-	-
050	63B5	95	-	115	-	140	-	-	-	-	-	-	-	-	11	11	11	11	11
	71B5/B14	110	70	130	85	160	105	14	14	14	14	14	14	14	14	14	14	14	-
	80B5/B14	130	80	165	100	200	120	19	19	19	19	19	19	19	-	-	-	-	-
063	71B5/B14	110	70	130	85	160	105	-	-	-	-	-	-	-	14	14	14	14	14
	80B5/B14	130	80	165	100	200	120	-	19	19	19	19	19	19	19	19	19	-	-
	90B5/B14	130	95	165	115	200	140	-	24	24	24	24	24	24	-	-	-	-	-
075	71B5	110	-	130	-	160	-	-	-	-	-	-	-	-	-	14	14	14	14
	80B5/B14	130	80	165	100	200	120	-	-	-	-	19	19	19	19	19	19	19	19
	90B5/B14	130	95	165	115	200	140	-	24	24	24	24	24	24	-	-	-	-	-
	100B5/B14	180	110	215	130	250	160	-	28	28	28	-	-	-	-	-	-	-	-
	112B5/B14	180	110	215	130	250	160	-	28	28	28	-	-	-	-	-	-	-	-
090	80B5/B14	130	80	165	100	200	120	-	-	-	-	-	-	-	19	19	19	19	19
	90B5/B14	130	95	165	115	200	140	-	24	24	24	24	24	24	24	24	24	-	-
	100B5/B14	180	110	215	130	250	160	-	28	28	28	28	28	28	-	-	-	-	-
	112B5/B14	180	110	215	130	250	160	-	28	28	28	28	28	28	-	-	-	-	-
110	80B5	130	-	165	-	200	-	-	-	-	-	-	-	-	-	-	-	19	19
	90B5	130	-	165	-	200	-	-	-	-	-	24	24	24	24	24	24	24	24
	100B5	180	-	215	250	-	-	28	28	28	28	28	28	28	28	28	-	-	-
	112B5	180	-	215	250	-	-	28	28	28	28	28	28	28	28	28	-	-	-
	132B5	230	-	265	300	-	-	38	38	38	38	-	-	-	-	-	-	-	-
130	90B5	130	-	165	-	200	-	-	-	-	-	-	-	-	-	-	24	24	24
	100B5	180	-	215	-	250	-	-	-	-	-	28	28	28	28	28	28	28	28
	112B5	180	-	215	-	250	-	-	-	-	-	28	28	28	28	28	28	28	28
	132B5	230	-	265	-	300	-	-	38	38	38	38	38	38	-	-	-	-	-
150	100B5	180	-	215	-	250	-	-	-	-	-	-	-	-	-	28	28	28	28
	112B5	180	-	215	-	250	-	-	-	-	-	-	-	-	-	28	28	28	28
	132B5	230	-	265	-	300	-	-	-	-	38	38	38	38	38	38	-	-	-
	160B5	250	-	300	-	350	-	-	42	42	42	42	42	-	-	-	-	-	-

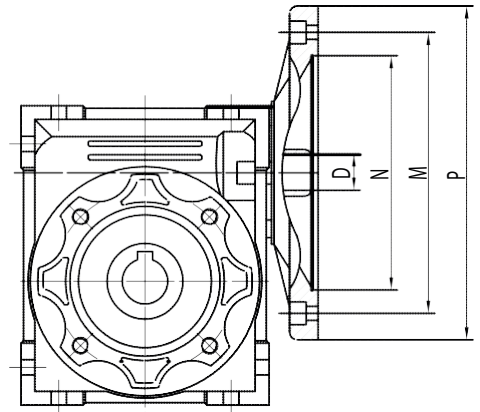

Size	Output Shaft Dimensions (SS, DS) Metric								
	d	T	T1	L1	Z	Z1	M	b1	t1
030	14(g6)	30	32.5	63	102	128	M6	5	16
040	18(h6)	40	43	78	128	164	M6	6	20.5
050	25(h6)	50	53.5	92	153	199	M10	8	28
063	25(h6)	50	53.5	12	173	219	M10	8	28
075	28(h6)	60	63.5	20	192	247	M10	8	31
090	35(h6)	80	84.5	40	234	309	M12	10	38
110	42(h6)	80	84.5	55	249	324	M16	12	45
130	45(h6)	80	85	70	265	340	M16	14	48.5
150	50(h6)	82	87	200	297	374	M16	14	53.5

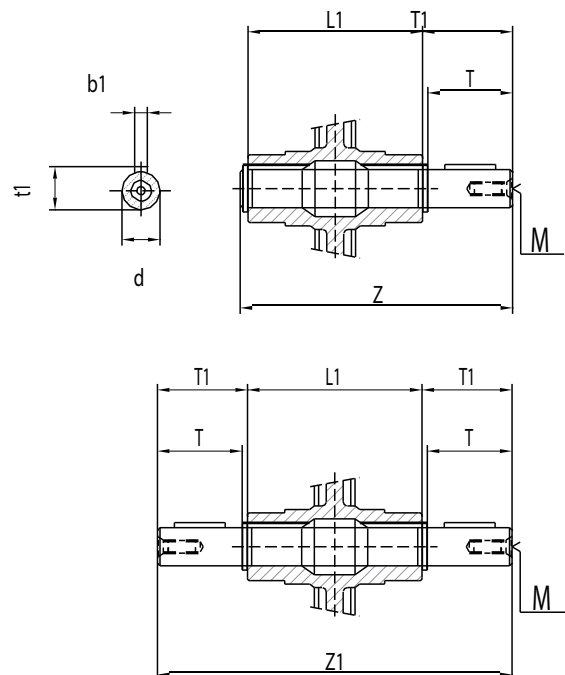

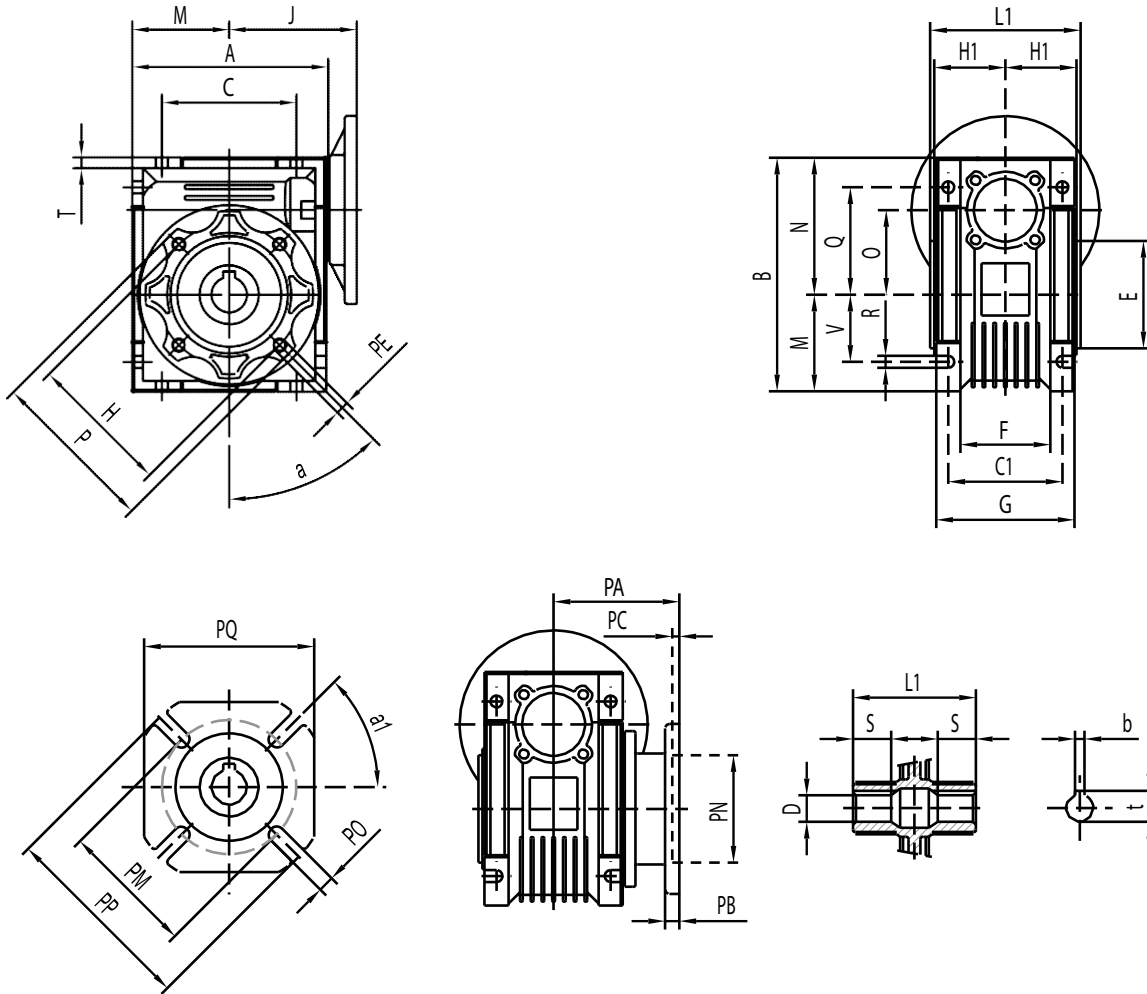

Size	A	B	C	C1	D	E	F	G	H	H1	J	L1	M	N	O	P	Q	R
030	81	97	54	44	14(h8)	55(h8)	32	56	65	29	55	63	40	57	30	75	44	6.5
040	101	121.5	70	60	18(h8)	60(h8)	43	71	75	36.5	70	78	50	71.5	40	87	55	6.5
050	121	144	80	70	25(h8)	70(h8)	49	85	85	43.5	80	92	60	84	50	100	64	8.5
063	146	174	100	85	25(h8)	80(h8)	67	103	95	53	95	112	72	102	63	110	80	8.5
075	174	205	120	90	28(h8)	95(h8)	72	112	115	57	115.5	120	86	119	75	140	93	11.5
090	208	238	140	100	35(h8)	110(h8)	74	130	130	67	129.5	140	103	135	90	160	102	13
110	252.5	295	170	115	42(h8)	130(h8)	-	144	165	74	160	155	127.5	167.5	110	200	125	14
130	292.5	335	200	120	45(h8)	180(h8)	-	155	215	81	180	170	147.5	187.5	130	250	140	16
150	340	400	240	145	50(h8)	180(h8)	-	185	215	96	210	200	170	230	150	250	180	18

Size	S	T	V	PA	PB	PC	PE	PM	PN	PO	PP	PQ	b	t	a	a1	kg
030	21	5.5	27	54.5	6	4	M6 (n=4)	68	50(h8)	6.5(n=4)	80	70	5	16.3	0°	45°	1.2
040	26	6.5	35	67	7	4	M6 (n=4)	75	60(h8)	9(n=4)	110	95	6	20.8	45°	45°	2.3
050	30	7	40	90	9	5	M8 (n=4)	85	70(h8)	11(n=4)	125	110	8	28.3	45°	45°	3.5
063	36	8	50	82	10	6	M8 (n=8)	150	115(h8)	11(n=4)	180	142	8	28.3	45°	45°	6.2
075	40	10	60	111	13	6	M8 (n=8)	165	130(h8)	14(n=4)	200	170	8	31.3	45°	45°	9
090	45	11	70	111	13	6	M10 (n=8)	175	152(h8)	14(n=4)	210	200	10	38.3	45°	45°	13
110	50	14.5	85	131	15	6	M10 (n=8)	230	170(h8)	14(n=8)	280	260	12	45.3	45°	45°	35
130	60	16	100	140	15	7	M12 (n=8)	255	180(h8)	16(n=8)	320	290	14	48.8	45°	22.5°	48
150	72.5	18	120	155	15	7	M12 (n=8)	255	180(h8)	18(n=8)	320	290	14	53.8	45°	22.5°	



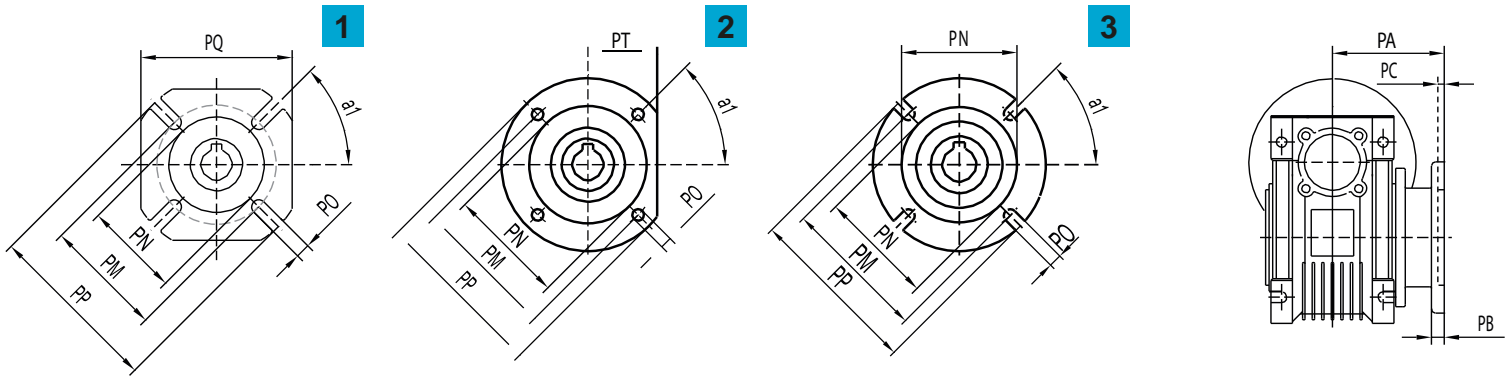

Size	030	040	050	063	075	090	110	130	150
FA	1	1	1	1	1	1	1	1	1
FB	-	1	1	1	3	2	1	-	-
FC	-	2	2	2	-	3	-	-	-

Size	PA	PB	PC	PN	PM	PO	PP	PQ	a1	PA	PB	PC	PN	PM	PO	PP	PQ	PT	a1	PA	PB	PC	PN	PM	PO	PP	PT	a1
	<b>FA</b>									<b>FB</b>									<b>FC</b>									
030	54.5	6	4	50	68	6.5(n=4)	80	70	45°	-	-	-	-	-	-	-	-	-	-	-	-	-	-	-	-	-	-	
040	67	7	4	60	75	9(n=4)	110	95	45°	97	7	4	60	75	9(n=4)	110	95	-	45°	80	9	5	95	115	9.5(n=4)	140	56	45°
050	90	9	5	70	85	11(n=4)	125	110	45°	120	9	5	70	85	11(n=4)	125	110	-	45°	89	10	5	110	130	9.5(n=4)	160	66	45°
063	82	10	6	115	150	11(n=4)	180	142	45°	112	10	6	115	150	11(n=4)	180	142	-	45°	98	10	5	130	165	11(n=4)	200	80	45°
075	111	13	6	130	165	14(n=4)	200	170	45°	90	13	6	130	130	11(n=4)	130	-	-	45°	-	-	-	-	-	-	-	-	-
090	111	13	6	152	175	14(n=4)	210	200	45°	122	18	6	180	215	14(n=4)	250	-	105	45°	110	17	6	130	165	11(n=4)	200	-	45°
110	131	15	6	170	230	14(n=8)	280	260	45°	-	-	-	-	-	-	-	-	-	-	-	-	-	-	-	-	-	-	-
130	140	15	6	180	255	16(n=8)	320	290	22.5°	-	-	-	-	-	-	-	-	-	-	-	-	-	-	-	-	-	-	-
150	155	15	6	180	255	18(n=8)	320	290	22.5°	-	-	-	-	-	-	-	-	-	-	-	-	-	-	-	-	-	-	-

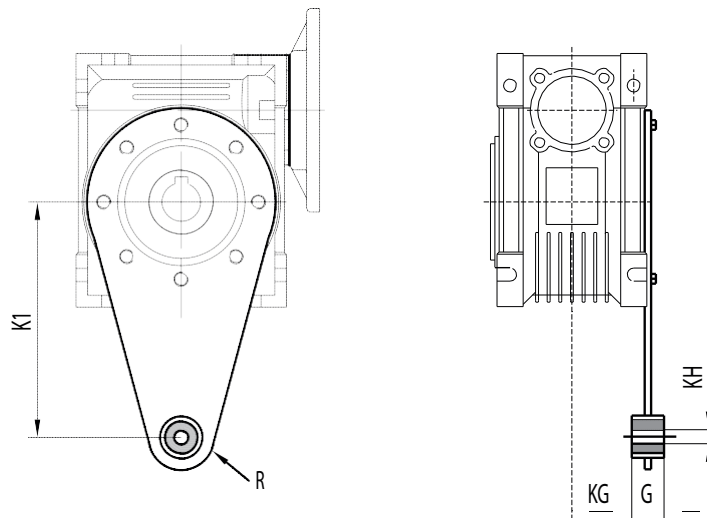

Size	030	040	050	063	075	090	110	130	150
K1	85	100	100	150	200	200	250	250	250
G	14	14	14	14	25	25	30	30	30
KG	24	31.5	38.5	49	47.5	57.5	62	69	84
KH	8	10	10	10	20	20	25	25	25
R	15	18	18	18	30	30	35	35	35

i	n2	030	040	040	063	075	090	110	130
5	280	599	1149	1586	2062	2428	2687	3389	4433
7.5	186	691	1325	1829	2378	2799	3098	3908	5112
10	140	758	1454	2007	2609	3072	3400	4288	5610
15	94	868	1665	2298	2988	3518	3893	4910	6424
20	70	954	1829	2525	3283	3865	4277	5395	7057
25	56	1033	1981	2735	3556	4187	4633	5844	7645
30	47	1088	2087	2881	3745	4410	4880	6155	8052
40	35	1204	2309	3188	4145	4880	5401	6812	8912
50	28	1296	2485	3431	4461	5252	5812	7331	9590
60	24	1381	2649	3658	4756	5599	6196	7815	10224
80	18	1516	2907	4014	5218	6144	6799	8576	11219
100	14	1638	3142	4338	5639	6639	7348	9268	12124

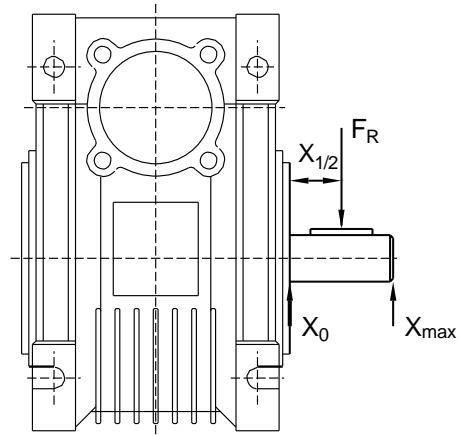

The information in the table above shows the permissible loading force on the midpoint of output shaft.

When the reducer is with double output shafts, the resultant radial force at the edge of the shaft should not exceed the values specified in the table above.

The maximum axial thrust permitted is 1/5 of radial force while the radial force and axial force are affected together.

# AMRV: Worm Reduction Gearbox Exploded View

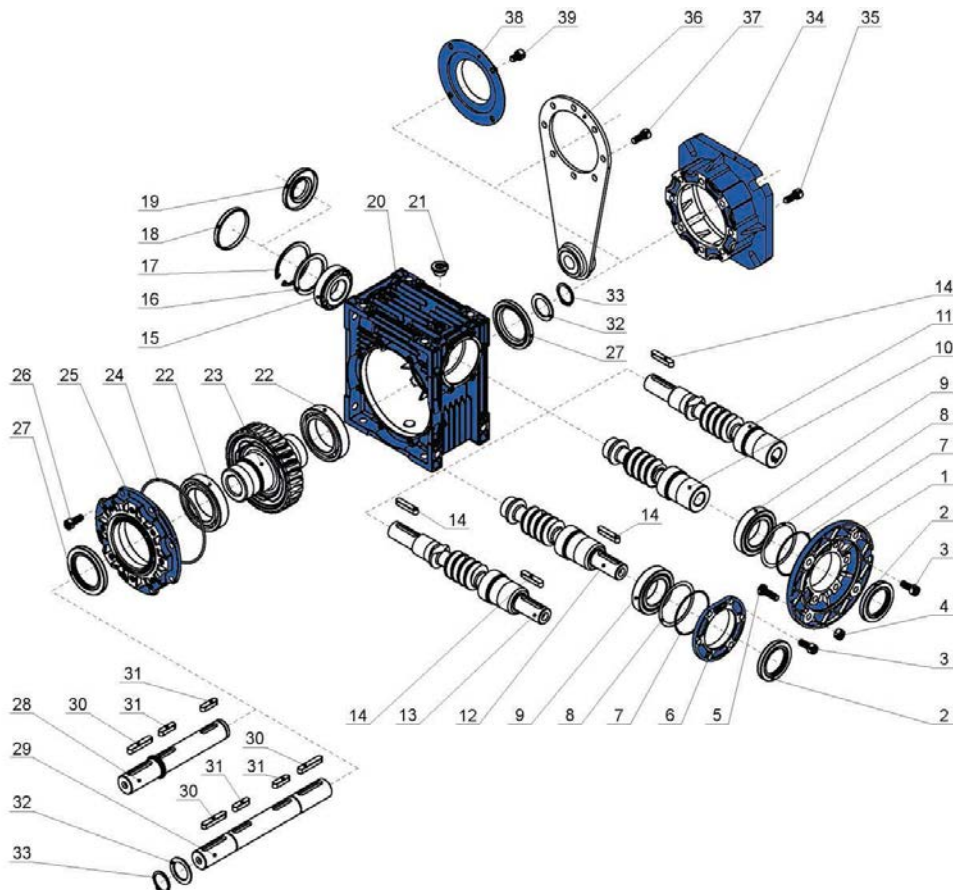

- |                                 |                         |                                  |                                  |
|---------------------------------|-------------------------|----------------------------------|----------------------------------|
| 1 Flange PAM                    | 11 Double ext. PAM worm | 21 Plug cock                     | 31 Parallel key                  |
| 2 Oli seal                      | 12 RV worm              | 22 Bearing                       | 32 SB Gasket                     |
| 3 Hexagon socket head cap screw | 13 Double ext. RV worm  | 23 Worm wheel                    | 33 Circlip for shaft             |
| 4 Hexagon nuts                  | 14 Parallel key         | 24 O-ring                        | 34 Output flange                 |
| 5 Hexagon bolt                  | 15 Bearing              | 25 Bearing support cover         | 35 Hexagon socket head cap screw |
| 6 Gear unit cover               | 16 Gasket               | 26 Hexagon socket head cap screw | 36 Torque arm                    |
| 7 O-ring                        | 17 Circlip for hole     | 27 Oli seal                      | 37 Hexagon socket head cap screw |
| 8 Spacer shim                   | 18 Cap                  | 28 single output shaft           | 38 Protection cap                |
| 9 Bearing                       | 19 Oli seal             | 29 Double output shaft           | 39 Hexagon socket head cap screw |
| 10 PAM worm                     | 20 Casing               | 30 Parallel key                  |                                  |

Rated output power $P_N$ (kW)	Nominal efficiency (%) for IE1 50Hz			Nominal efficiency (%) for IE2 50Hz			Nominal efficiency (%) for IE3 50Hz		
	2 Pole	4 Pole	6 Pole	2 Pole	4 Pole	6 Pole	2 Pole	4 Pole	6 Pole
0.75	75.0	73.0	69.0	77.4	79.6	75.9	80.7	82.5	78.9
1.1	77.0	75.0	72.0	79.6	81.4	78.1	82.7	84.1	81.0
1.5	79.0	78.0	76.0	81.3	82.8	79.8	84.2	85.3	82.5
2.2	81.0	80.0	79.0	83.2	84.3	81.8	85.9	86.7	84.3
3	83.0	82.0	81.0	84.6	85.5	83.3	87.1	87.7	85.6
4	85.0	84.0	82.0	85.8	86.6	84.6	88.1	88.6	86.8
5.5	86.0	96.0	84.0	87.0	87.7	86.0	89.2	89.6	88.0
7.5	87.0	87.0	86.0	88.1	88.7	87.2	90.1	90.4	89.1
11	88.0	88.0	87.5	89.4	89.8	88.7	91.2	91.4	90.3
15	89.0	89.0	89.0	90.3	90.6	89.7	91.9	92.1	91.2
18.5	90.0	90.5	90.0	90.9	91.2	90.4	92.4	92.6	91.7
22	90.5	91.0	90.0	91.3	91.6	90.9	92.7	93.0	92.2
30	91.2	92.0	91.5	92.0	92.3	91.7	93.3	93.6	92.9
37	92.0	92.5	92.0	92.5	92.7	92.2	93.7	93.9	93.3
45	92.3	92.8	92.5	92.9	93.1	92.7	94.0	94.2	93.7
55	92.5	93.0	92.8	93.2	93.5	93.1	94.3	94.6	94.1
75	93.0	93.8	93.5	93.8	94.0	93.7	94.7	95.0	94.6
90	93.8	94.2	93.8	94.1	94.2	94.0	95.0	95.2	94.9
110	94.0	94.4	94.0	94.3	94.5	94.3	95.2	95.4	95.1
132	94.5	94.6	94.2	94.6	94.7	94.6	95.4	95.6	95.4
160	94.6	94.7	94.5	94.8	94.8	94.8	95.6	95.8	95.6

## Maximum safe rpm

Safe running speeds for squirrel-cage induction motors. Unless the name plate states otherwise, all AmTecs 3 phase induction motors smaller than 315 frame, can safely run continuously at the speed in the following table.

Frame Size	2 Pole	4 Pole	6 Pole
≤ 100	5200	3600	2400
112	5200	3600	2400
132	4500	2700	2400
160	4500	2700	2400
180	4500	2700	2400
200	4500	2300	1800
225	3600	2300	1800
250	3600	2300	1800
280	3600	2300	1800
315	3600	2300	1800

*Note: Motors can run above the rated speed when used in conjunction with a frequency inverter. However, noise and vibration will increase. It can be necessary to have the motors corrected to support continued running above the speeds stated above. Prolonged running at higher speed will effect the bearing life and where applicable the re-greasing intervals.*

# Maximum A-weighted sound power level

Maximum A-weighted sound power level, LwA in dB, at no-load.

For single speed three-phase cage induction motors IC01, IC11, IC21, IC411, IC511, IC611

Frame size	2 Pole	4 Pole	6 Pole	8 Pole
	<b>2 Pole</b>	<b>4 Pole</b>	<b>6 Pole</b>	<b>8 Pole</b>
	Sound pressure LWA (dB)	Sound pressure LWA (dB)	Sound pressure LWA (dB)	Sound pressure LWA (dB)
<b>90</b>	78	66	63	63
<b>100</b>	82	70	64	64
<b>112</b>	83	72	70	70
<b>132</b>	85	75	73	71
<b>160</b>	87	77	73	72
<b>180</b>	88	80	77	76
<b>200</b>	90	83	80	79
<b>225</b>	92	84	80	79
<b>250</b>	92	85	82	80
<b>280</b>	94	88	85	82
<b>315</b>	98	94	89	88
<b>355</b>	100	95	94	92

Note 1: Motors with cooling method IC01, IC11, IC21 may present higher sound Power levels: 2 and 4 poles +7dB( A ), - 6 and 8 poles +4dB( A ).

Note 2: Sound power levels for 2 and 4 poles, frame sizes greater than 315 are valid for unidirectional fans. All other sound Power levels are valid for bidirectional fans.

Note 3: The values for 60 Hz motors should be increased as follows : 2 poles +5dB( A ) ; 4, 6 and 8 poles +3dB( A ).

# Maximum Expected increase over no load condition

Maximum expected increase, over no-load condition, in A-weighted sound power levels, LWA in dB, for rated load condition.

Frame Size	2 Pole	4 Pole	6 Pole	8 Pole
<b>90 -160</b>	2	5	7	8
<b>180-200</b>	2	4	6	7
<b>225-280</b>	2	3	6	7
<b>315</b>	2	3	5	6
<b>355</b>	2	2	4	5

Note 1: This table provides the maximum expected increment at rated load conditions to be added to any declared no-load value.

Note 2: the values apply to both 50 Hz and 60 Hz supplies.

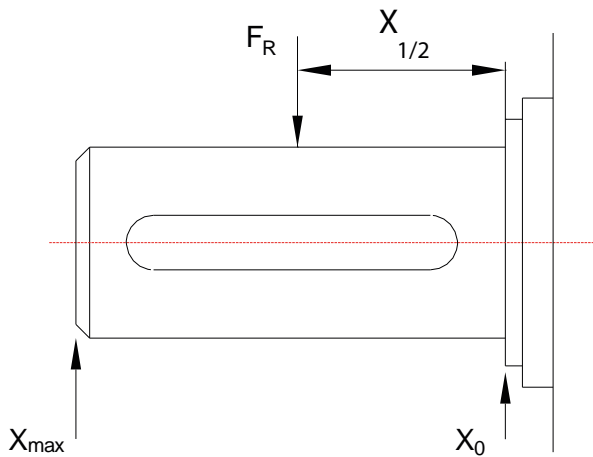

The following table gives the permissible radial forces in Newtons, assuming zero axial force. This table shows loadings for standard ball bearings. For higher radial loads than given a reinforced bearing should be fitted.

The Values are based on normal operating conditions at 50Hz and calculated at 20,000 working hours for 2 pole and 40,000 working hours for 4, 6, and 8 pole motors. At 60Hz the values should be reduced by 10%.

The minimum pulley diameter can be calculated with the following formula:

$$D = \frac{1.9 \times 10^7 \times k \times P_N}{n_N \times F_R}$$

- D = Diameter of the pulley (mm)
- $P_N$  = Power of the motor (kW)
- $n_N$  = Motor rated speed (r/min)
- k = Belt tension factor, k=2.5 for V-belt
- $F_R$  = Permissible radial force (N)

Frame size	Pole	Maximum radial force ( $F_R$ )		
		X0	X 1/2	X Max
56	2	250	180	100
56	4	250	180	100
63	2	260	300	230
63	4	260	300	230
71	2	470	400	320
71	4	470	400	320
71	6	470	400	320
80	2	670	610	550
80	4	730	650	590
80	6	830	750	680
80	8	920	820	750
90	2	740	660	590
90	4	800	710	630
90	6	920	810	730
90	8	1010	890	800
100	2	1030	920	820
100	4	1110	990	890
100	6	1270	1130	1020
100	8	1400	1240	1120
112	2	1490	1330	1200
112	4	1600	1430	1290
112	6	1840	1640	1480
112	8	2020	1800	1630
132	2	2160	1900	1690
132	4	2330	2040	1820
132	6	2670	2340	2080
132	8	2940	2570	2290
160	2	2800	2440	2170
160	4	3000	2630	2330
160	6	3440	3010	2670
160	8	3850	3410	3060
180	2	3930	3500	3150
180	4	4240	3770	3390
180	6	4890	4390	3980
180	8	5380	4830	4380
200	2	4480	4050	3700
200	4	4820	4360	3980
200	6	5520	5000	4560
200	8	6080	5500	5020
225	2	5000	4540	4160
225	4	5360	4720	4210
225	6	6180	5480	4920
225	8	6750	5940	5310
250	2	5680	5100	4620
250	4	6120	5490	4980
250	6	7000	6280	5700
250	8	7710	6920	6270
280	2	5620	5080	4640
280	4	7790	7050	6430
280	6	8920	8060	7360
280	8	9820	8880	8100
315	2	7370	6840	6390
315	4	9150	8370	7720
315	6	10480	9590	8830
315	8	11530	10550	9720
355*	2	16330	15390	8730
355*	4	28300	25860	14290
355*	6	32400	29600	16350
355*	8	35660	32500	18000

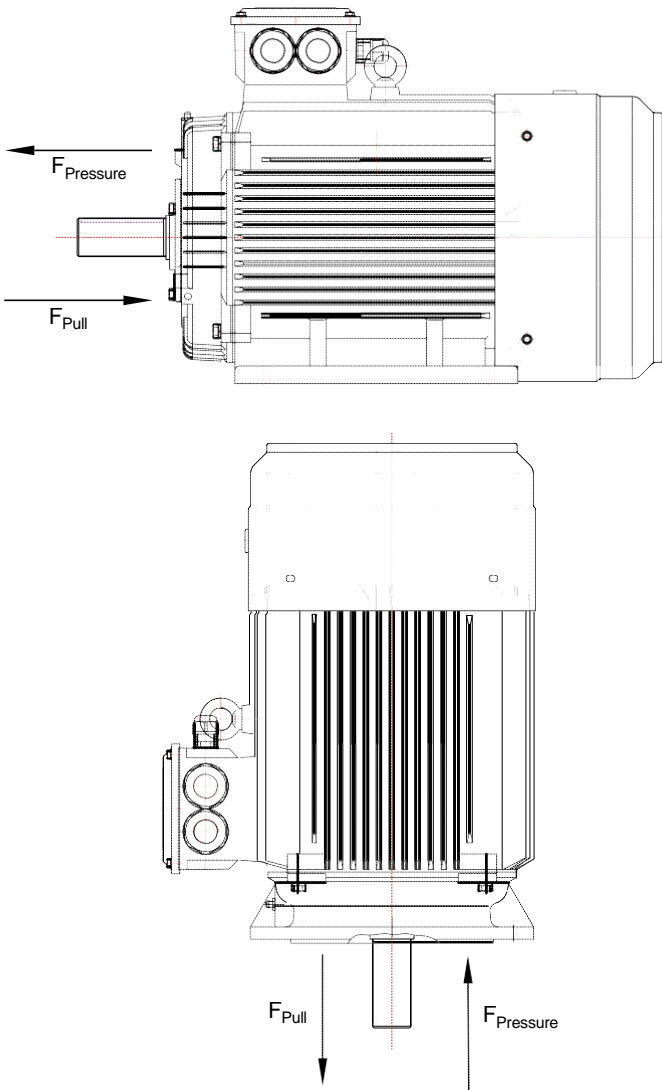

Frame size	Pole	Maximum axial force ( $F_A$ )			
		B3 F Pressure	B3 F Pull	V1 F Pressure	V1 Pull
56	2	200	200	230	180
56	4	240	240	260	200
63	2	250	250	260	230
63	4	280	280	300	260
71	2	270	270	290	255
71	4	350	350	370	320
71	6	440	440	460	420
80	2	380	380	400	360
80	4	470	470	490	450
80	6	590	590	620	560
80	8	620	620	650	595
90	2	440	440	470	410
90	4	550	550	600	510
90	6	620	620	680	460
90	8	640	640	700	580
100	2	610	610	670	570
100	4	750	750	840	710
100	6	880	880	970	820
100	8	895	895	970	845
112	2	1220	1220	1300	1170
112	4	1440	1440	1520	1370
112	6	1650	1650	1740	1580
112	8	1780	1780	1880	1710
132	2	1500	1500	1620	1430
132	4	1780	1780	1970	1610
132	6	1820	1820	2000	1660
132	8	1920	1920	2100	1760
160	4	2100	2100	2470	1720
160	6	2450	2450	2800	2050
160	8	2650	2650	3050	2210
180	2	2100	2100	2450	1720
180	4	2600	2600	3200	2000
180	6	2900	2900	3510	2280
180	8	3170	3170	3780	2550
200	2	2400	2400	2940	1840
200	4	3120	3120	3550	2390
200	6	3480	3480	4350	2610
200	8	3950	3950	4810	3090
225	2	2720	2720	3420	2020
225	4	3480	3480	4370	2590
225	6	3890	3890	5040	2820
225	8	4330	4330	5330	3330
250	2	3100	3100	3940	2260
250	4	3900	3900	5000	2800
250	6	4450	4450	5570	3230
250	8	4980	4980	6380	3580
280	2	5300	3100	6500	2100
280	4	6300	4400	7800	3000
280	6	6700	4300	7900	2900
280	8	7100	5020	9100	3520
315	2	5900	3800	8000	2000
315	4	7100	5100	10700	3150
315	6	7600	5800	11800	3500
315	8	8100	6300	12500	4400
355*	2	6100	1850	14000	1800
355*	4	9800	3900	18300	2500
355*	6	10500	4700	20700	3500
355*	8	12500	6000	21500	3600

The following table gives the permissible axial forces in Newtons, assuming zero radial force. This table shows loadings for standard ball bearings. For higher axial loads an angular contact bearing should be fitted.

The Values are based on normal operating conditions at 50Hz and calculated at 20,000 working hours for 2 pole and 40,000 working hours for 4, 6, and 8 pole motors. At 60Hz the values should be reduced by 10%.

$F_{Pressure}$  is calculated for a fixed drive end bearing.

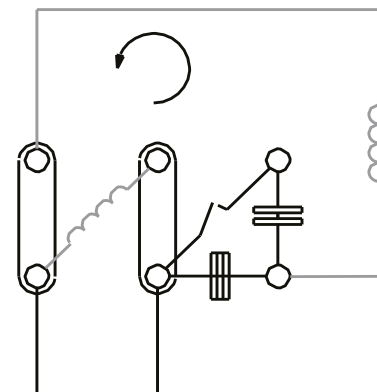
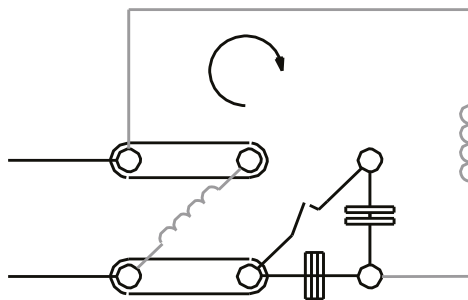
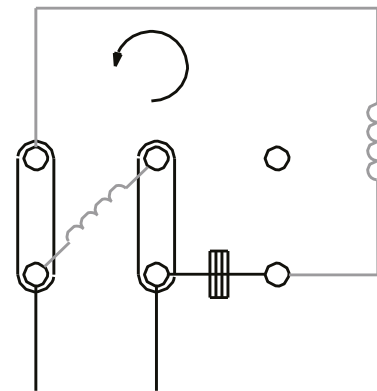
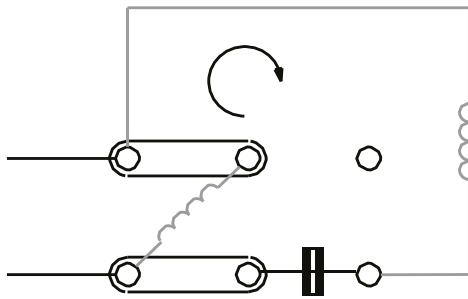
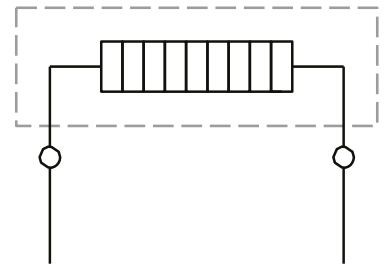
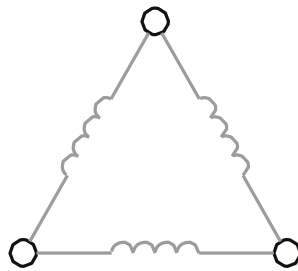
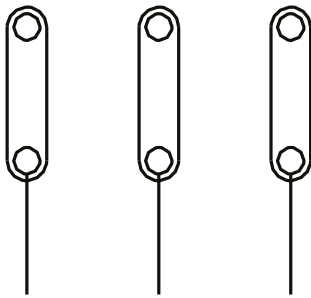
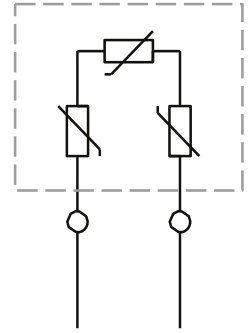
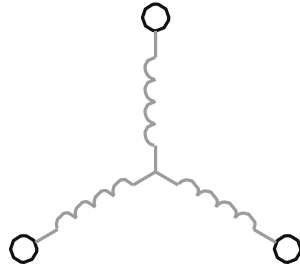
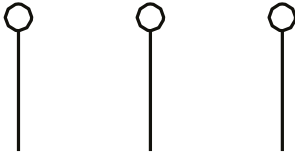



## Insulation Class

AmTecs motors are built using a class F insulation system. On request insulation class H may also be supplied. Thermal class F allows temperature increases (according to the resistance variation method) of 105°C with a maximum ambient temperature of 40°C and maximum temperatures of 155°C. In addition, the process of impregnation with a tropicalized varnish confers a higher degree of protection to the motor, against damaging atmospheric agents, including a high level of humidity (up to 90%), temperature changes, parasites, etc. In the special case of class H windings, motors can be used in high-temperature environments or in extreme conditions.

## Overheating

Below, we show data regarding permitted overheating for indirect air-cooled machines, for the power range up to 200kW calculated according to the “superposition” test method. It is thus possible to exceed the temperature rise limits by 5°C, for classes A, E, B, F.

The maximum limit temperatures of the insulation classes defined in regulation EN 60034-1 are shown.

Class	ΔT (°C)	Temperature limit °C
A	60+5°	105
E	75+5°	120
B	80+5°	130
F	105+5°	155
H	125+5°	180

In general, AmTecs motors are built in order not to exceed a temperature-rise limit of 80°C under normal conditions of use (at ambient temperature of 40°C, altitude of less than 1000meters, rated load, rated voltage and frequency). Use at extreme values of voltage (± 10% of nominal voltage) results in overheating of less than 10%.

According to regulation EN 60034-1, the temperature rise should be calculated using the winding-resistance method, using the following equation. This guarantees a good margin of safety under normal conditions of use:

$$\Delta T = \frac{R_2 - R_1}{R_1} (235 + T_1)$$

$R_1$ : Resistance cold, measured at ambient temperature  $T_1$   
 $R_2$ : Resistance stabilised hot, measured at ambient temperature  $T_2$   
 235: coefficient corresponding to a copper winding.

Protection against penetration of water or dust is ensured by a seal mounted behind the endshield. The seals have good resistance to vibration and good thermal stability, and are resistant to mineral oils and dilute acids. On request, seals are available in Viton.

1 <sup>st</sup> number	Protection against contact and ingress of foreign bodies definition
0	No Protection
1	Protection against foreign bodies larger than 50mm (Example: Inadvertent contact with the hand)
2	Protection against foreign bodies larger than 12mm (Example: Inadvertent contact with the fingers)
3	Protection against foreign bodies larger than 2.5mm (Example: Small tools)
4	Protection against foreign bodies larger than 1mm (Example: Small tools, Wires)
5	Protection against dust (harmful deposits of dust)
6	Complete protection against dust

2 <sup>nd</sup> number	Protection against ingress of water definition
0	No Protection
1	Protection against vertically falling water drops (condensation)
2	Protection against dripping water when inclined by up to 15°
3	Protection against water spray at up to 60° from vertical
4	Protection against water splashed from any direction
5	Protection against water projected by a nozzle from any direction
6	Protection against heavy seas or water projected in powerful jets
7	Protection when submerged between 0.15m and 1m
8	Protection when continuously submerged in water at conditions agreed between the manufacturer and the user

Motors are normally wound for a rated supply of 380-415Volts and a frequency of 50Hz. However, motors for any standard supply from 110V to 660V at frequencies of 50Hz and 60Hz may be supplied on request.

Motors will operate satisfactorily with a voltage band of  $\pm 6\%$  of the rated voltage. In case of continuous operation at the extreme voltage limits specified above, the temperature rise limits permitted for various insulation classes may be exceeded by 10K maximum.

Motors wound for 50Hz may generally be connected to a 60Hz supply. In this case the speed will increase by 20% with reference to rated voltages at 50Hz, the approximate multipliers to obtain the new performance values at 60Hz are given in the following table.

50Hz		60Hz performance data at full load					
Rated voltage (V)	Supply voltage (V)	Rated output power $P_N$ (kW)	Full-load speed $n_N$ (min <sup>-1</sup> )	Rated current $I_N$ (A)	Full-load torque $M_N$	Starting current $I_s / I_N$	Starting torque $M_A / M_N$
230 Voltage (220-240)	220	1	1.2	1	0.83	0.83	0.72
	240	1	1.2	1	0.83	0.91	0.78
	255	1.1	1.2	1	0.92	0.96	0.90
	265	1.15	1.2	1	0.96	1	0.93
	277	1.2	1.2	1	1	1.03	0.98
400 Voltage (380-415)	380	1	1.2	1	0.83	0.83	0.72
	415	1	1.2	1	0.83	0.91	0.78
	440	1.1	1.2	1	0.92	0.96	0.90
	460	1.15	1.2	1	0.96	1	0.93
	480	1.2	1.2	1	1	1.06	0.98

## Environmental Conditions

If our standard range motors are operated at an ambient temperature beyond 40°C and altitude over 1000m above sea level, their rated outputs will change at the ratios given below.

If ambient temperature and altitude both vary, multiply the rated output with its respective factors to obtain the new permitted output. If the output reduction exceeds 15%, please consult us as the operating characteristics of the motor will become unfavourable due to its utilization factor.

Ambient temp	°C	≤30	30..40	45	50	55	60
Rated output	%	107	100	95	90	85	80

Altitude	M	1000	2000	3000	4000
Rated output	%	100	95	90	80

At altitudes over 1000m, the rated output of a motor will remain unchanged if the ambient temperature of 35°C drops by 1.0°C for insulation class F, 1.25°C for insulation class H for every 100m increment of altitude.

