

How do I wire a 3 Phase electric motor?

On delivery the motor will rotate clockwise looking at the drive when the phase L1, L2 and L3 are connected to the connection terminals U1, V1 and W1. Exchanging any two-phase lines can change the direction of rotation.

Connecting cables must conform to IEE regulations, as must earthing requirements.

Line fuses only protect the cables in case of short circuit and do not constitute a safeguard against the overheating of the winding caused by overload. Therefore it is recommended that a motor starter and overload is fitted, giving single phasing and overload protection.

Normally our motors are provided with a terminal box with six connections, to which six leads from the winding are connected either in a delta connection or in a star connection by means of connection links.

Usually two voltages are indicated on the rating-plate of these motors, which means that the motor can be connected to a circuit having one of these voltages. If the mains voltage is corresponding with the lowest indicated voltage, the winding has to be connected in delta connection, if it is corresponding with the highest indicated voltage, the winding has to be connected in star connection.

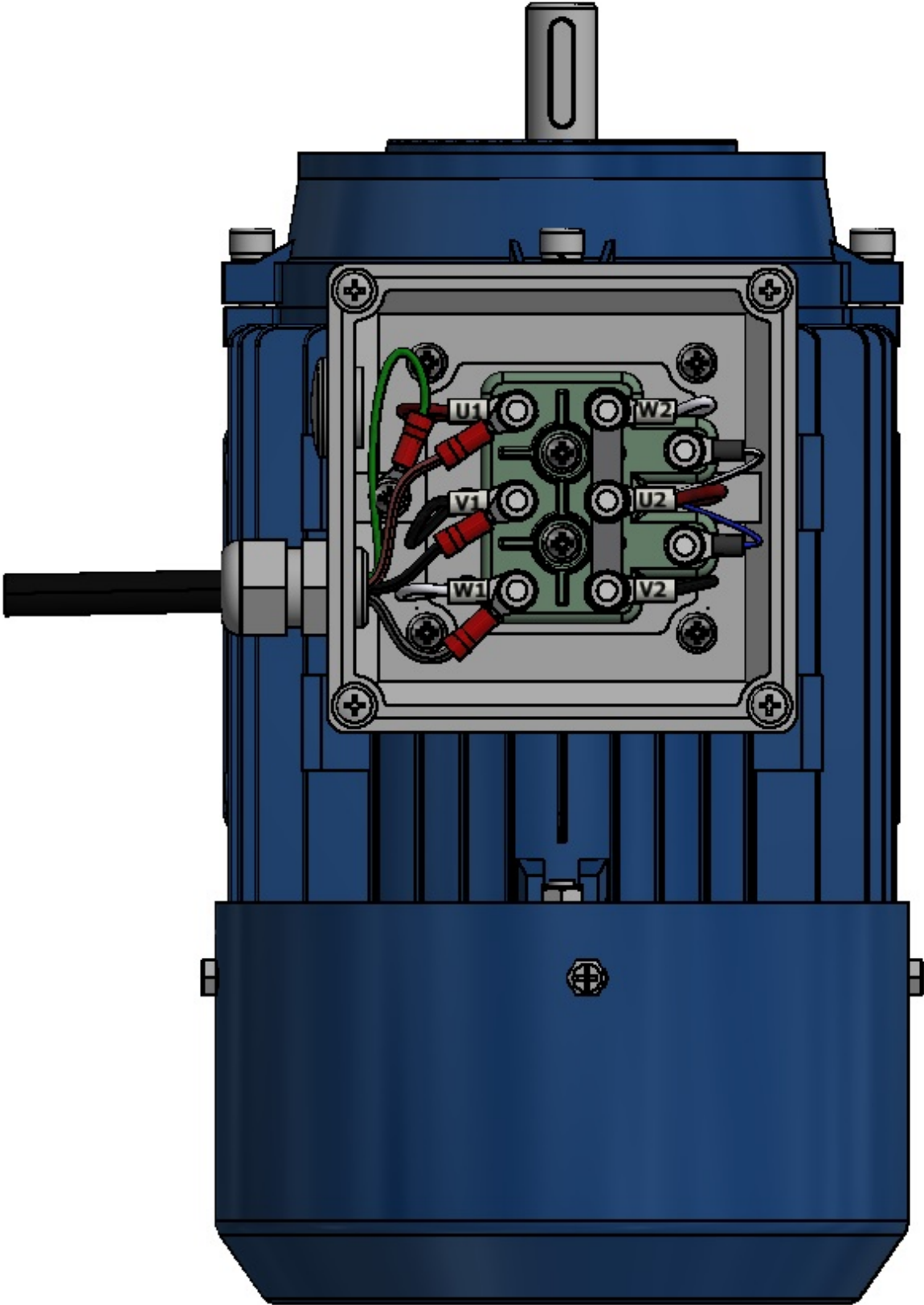

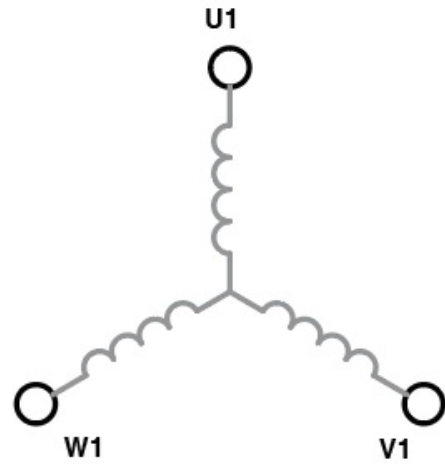
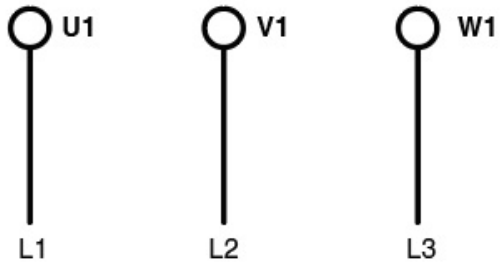

Star Configuration

If the supply is 415V and the motor's nameplate shows both the following voltage ranges:

Y 380-420 V

D 220-240 V

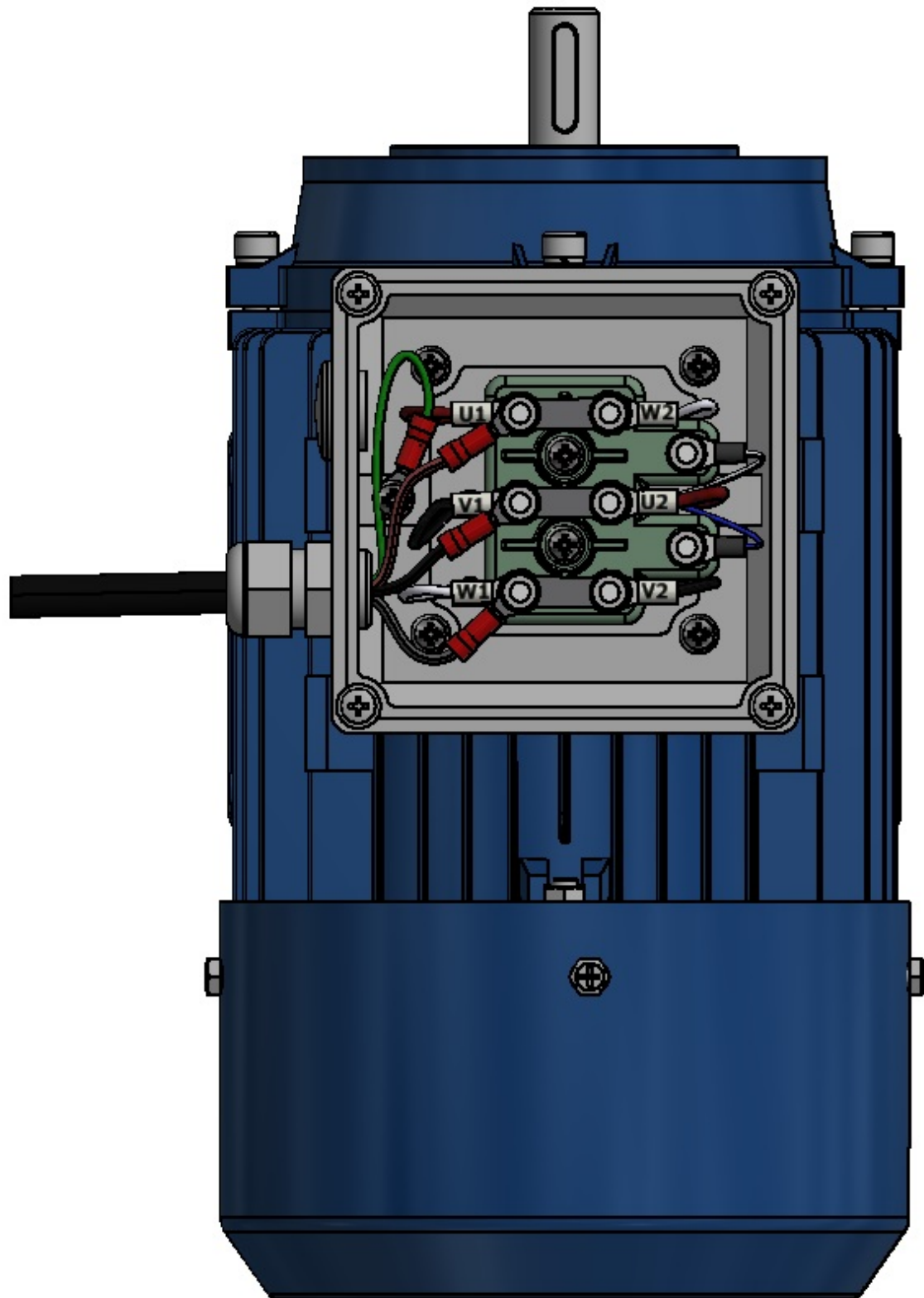

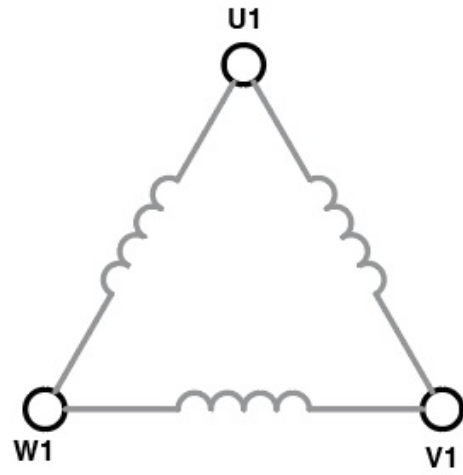
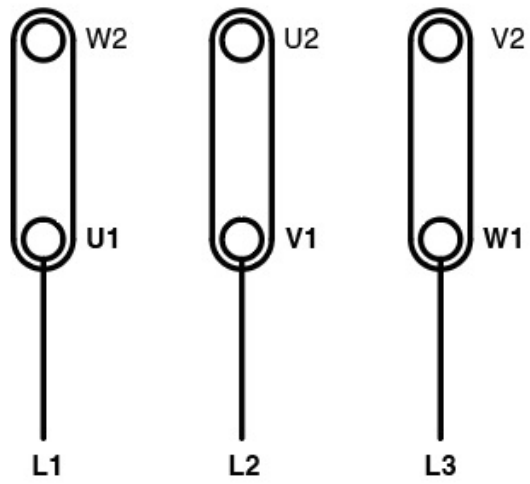

Delta Configuration

If the supply is 415V and the motors nameplate shows both the following voltages ranges:

Y 660-720 V

D 380-420 V